



# Reflex 105

Multi-Sided Inset Convector Fire Range  
with Harmony 10 Remote Control System



## Installation Instructions

### IMPORTANT

THE OUTER CASING, FRONT AND GLASS PANEL BECOME EXTREMELY HOT DURING OPERATION AND WILL RESULT IN SERIOUS INJURY AND BURNS IF TOUCHED. IT IS THEREFORE RECOMMENDED THAT A FIREGUARD COMPLYING WITH BS 8423 (LATEST EDITION) IS USED IN THE PRESENCE OF YOUNG CHILDREN, THE ELDERLY OR INFIRM.

This product contains a Heat resistant glass panel. This panel should be checked during Installation and at each servicing interval. If any damage is observed on the front face of the glass panel (scratches, scores, cracks or other surface defects), the glass panel must be replaced and the appliance must not be used until a replacement is installed. Under no circumstances should the appliance be used if any damage is observed, the glass panel is removed or broken.

It is essential that ALL of the screws that retain the glass frame are replaced and tightened correctly. Under no circumstances should the appliance be operated if any of these screws are loose or missing.

These Instructions must be left with the appliance for future reference and for consultation when servicing the appliance. Please make the customer aware of the correct operation of the appliance before leaving these instructions with them.

The commissioning sheet found on Page 3 of this Instruction manual must be completed by the Installer prior to leaving the premises.

THIS APPLIANCE MUST BE EARTHED

PR2778.6.06.2024

# CONTENTS

## REFLEX 105 MULTI-SIDED - BALANCED FLUE

NAT GAS	LPG
191-014	191-405

**Appliance Commissioning Checklist .....3**

**User Instructions .....4**

**Installation Instructions ..... 11**

Dimensions..... 13

Technical Specifications ..... 14

Flue Options ..... 18

Mounting Bracket ..... 20

Pre-Installation..... 22

Enclosure Construction ..... 27

Installation ..... 38

Commissioning ..... 46

**Servicing Instructions.....47**

Fault Finding..... 47

Replacing Parts ..... 50

Spare Parts List..... 64

Information Requirement - Gas Heaters ..... 66

Service Records ..... 67



It is a requirement of the Building Regulations 2010 that the installation of this appliance is notified to the Local Authority. It is the responsibility of the GasSafe registered installer to carry out this notification to the Local Authority via the GasSafe register Competent Persons Scheme in England and Wales (different rules apply in Scotland and Northern Ireland).

When the installation has been notified, GasSafe will send a Building Regulations Compliance Certificate to you containing details of the work completed. Please ensure that the person responsible for the installation of this appliance completes this notification and records it in the Appliance Commissioning Checklist on page 3.

**IT IS YOUR RESPONSIBILITY TO COMPLY WITH THE BUILDING REGULATIONS AND BE ABLE TO PRODUCE THIS CERTIFICATE SHOULD IT BE REQUIRED IN THE FUTURE.**

# APPLIANCE COMMISSIONING CHECKLIST

To assist us in any guarantee claim please complete the following information:-

## IMPORTANT NOTICE

Explain the operation of the appliance to the end user, hand the completed instructions to them for safe keeping, as the information will be required when making any guaranteed claims.

FLUE CHECK	PASS	FAIL
1. Flue Is correct for appliance		
2. Flue flow Test N/A		
3. Spillage Test N/A		
GAS CHECK		
1. Gas soundness & let by test		
2. Standing gas pressure	mb	
3. Appliance working pressure (on High Setting) Minimum Pressure Requirement: NG - 16.5mbar LPG - 34.5mbar NB All other gas appliances must be operating on full	mb	
4. Gas rate	m <sup>3</sup> /h	
5. Does Ventilation meet appliance requirements N/A		
SAFETY CHECK		
1. Check soundness of the Thermocouple connections - including tightness and lead integrity		
2. Glass checked to ensure no damage, scratches, scores or cracks		
3. Glass frame secured correctly and all screws replaced		
4. CO alarm fitted		
BUILDING CONTROL NOTIFICATION	YES	NO
1. Installer notified GasSafe/Local Authority of installation via Competent Persons Scheme?		

## RETAILER AND INSTALLER INFORMATION

**Retailer** .....

.....

.....

**Contact No.** .....

**Date of Purchase**.....

**Model No.**.....

**Serial No.** .....

**Gas Type**.....

**Installation Company** .....

.....

.....

**Engineer**.....

**Contact No.**.....

**GasSafe Reg No.** .....

**Date of Installation** .....

## USER INSTRUCTIONS

### GENERAL

Installation and servicing must only be carried out by a competent person whose name appears on the Gas Safe register. To ensure the engineer is registered with Gas Safe they should possess an ID Card carrying the following logo:



In all correspondence, please quote the appliance type and serial number, which can be found on the data badge located on a plate under the Main Burner.

Do not place curtains above the appliance:  
You must have 500mm clearance between the appliance and any curtains at either side.

No furnishings or other objects should be placed within 1 metre of the front of the appliance.

If any cracks appear in the glass panels do not use the appliance until the panels have been replaced.

Do not obstruct the flue terminal in any way, i.e. by planting flowers, trees, shrubs etc. in the near vicinity, or by leaning objects against the terminal guard.

Do not put any objects on the terminal guard; it will lose its shape.

If you use a garden sprinkler, do not let quantities of water into the flue terminal.

When the appliance has been installed the position of the plug must be accessible.

Where the electricity supply cable has to pass through a **fire place, stone surround etc. ensure suitable rubber bushes are fitted at possible wear points.**

If the electricity supply cable is damaged do not use the appliance until it has been replaced. For safety reasons the replacement has to be carried out by Gazco, a Gazco service agent or a similarly competent electrician.

Repairs of electrical appliances must only be performed by an electrical engineer. Should the appliance fail to operate, or in case of any damage, please contact the retailer from whom the appliance was purchased.

This product is guaranteed for 5 years from the date of installation, as set out in the terms and conditions of sale between Gazco and your local Gazco retailer. Please consult with your local Gazco retailer if you have any questions. In all correspondence always quote the Model Number and Serial Number.

**This appliance is not intended to be used by persons under the age of 12, persons with reduced physical, sensory or mental capabilities or persons with lack of experience and knowledge in the safe operation of the appliance.**

The appliance may be operated by persons above the age of 12 provided they have been instructed in the safe use of the appliance and that they understand the hazards involved. Persons above the age of 12 may also operate the appliance under the supervision of a responsible adult.

Cleaning and Maintenance of the appliance must be undertaken by a suitably qualified adult.

**CHILDREN MUST BE SUPERVISED TO ENSURE THEY DO NOT PLAY WITH THE APPLIANCE.**



**IMPORTANT: NEVER position a television or screen above this appliance.**

### CO ALARMS

Building regulations require that whenever a new or replacement fixed gas burning appliance is installed in a dwelling, a carbon monoxide alarm complying with BS EN 50291-1 (latest edition) must be fitted in the same room as the appliance. Further guidance and recommendations on the installation of carbon monoxide alarms is available in BS EN 50292 (latest edition) and from manufacturers' instructions.

**Provision of an alarm must not be considered a substitute for either installing the appliance correctly or ensuring regular servicing and maintenance of the appliance.**

## OPERATING THE APPLIANCE

The appliance is operated by thermostatic and programmable remote control.

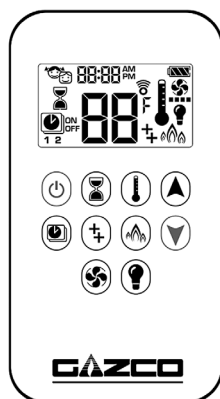

Via the remote it is possible to control the following features:

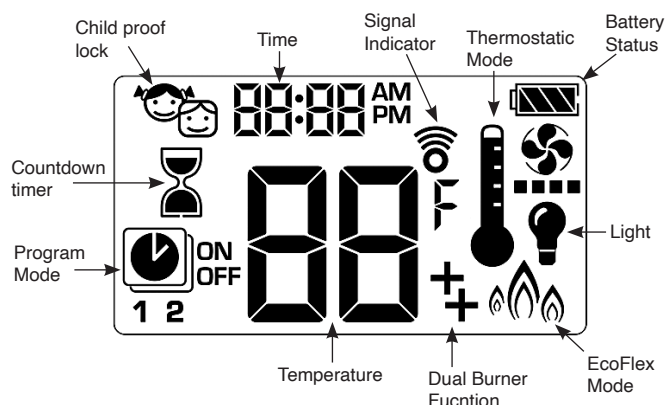

## TURNING THE APPLIANCE ON

The handset controls the appliance from pilot ignition through to shut down.

To turn the fire on press the  button until two short signals and a series of blinking series of lines confirm the start of the ignition sequence.

**The pilot will ignite and the remote is now in Manual Mode:**

**IMPORTANT: YELLOW FLAMES TYPICALLY APPEAR WHEN THE APPLIANCE HAS REACHED NORMAL OPERATING TEMPERATURE. THIS CAN TAKE UP TO 30 MINUTES.**

**WARNING: IF THE APPLIANCE FAILS TO LIGHT OR BECOMES EXTINGUISHED IN USE, WAIT 3 MINUTES BEFORE ATTEMPTING TO RELIGHT.**

There are 4 different modes available for controlling and operating the appliance:

1. Manual Mode
2. Thermostatic Mode (Automatic)
3. Program Mode (Automatic)
4. EcoFlex Mode (Automatic)

In **MANUAL MODE** you can:

- turn on the main burner using the  button.
- regulate the flame from high to low and back.
- turn off the burner leaving just the pilot burning.

In **THERMOSTATIC MODE (Automatic)** you can:

- set the room temperature so the thermostat in the remote automatically maintains that temperature.

In **PROGRAM MODE (Automatic)** the fire:

- turns on and off according to the set time periods.
- automatically regulates the room temperature during the set periods.

In **ECOFLEX MODE (Automatic)** the fire:

- modulates the flame height between high and low in response to room temperature. One cycle lasts for 20 minutes.

**NOTE:** When operating the fire in Thermostatic or Program mode, the pilot remains lit and the fire then automatically switches on to bring the room to the set temperature whether or not you are in the room.

**NEVER LEAVE ANY COMBUSTIBLE MATERIALS WITHIN 1 METRE OF THE FRONT OF THE APPLIANCE.**

## TURNING THE APPLIANCE OFF (STANDBY)

Press and hold the  button to turn the appliance off.

**NOTE:** There is a 5 second delay before the next ignition is possible.

## MANUAL MODE

To turn the fire on press the  button until two short signals and a series of blinking series of lines confirm the start of the ignition sequence.

**Standby By (Pilot Flame) Mode:**

Press and hold the  button to set the appliance to pilot flame only.

**FOR SAFETY, YOU MUST WAIT 30 SECONDS BEFORE LIGHTING THE FIRE AGAIN.**

**Increasing the Flame Height:**

To increase flame height press and hold  button.

**Decreasing the Flame Height:**

To decrease flame height press or to set the appliance to pilot flame and hold the  button.

**NOTE:** While pressing a button a symbol indicating transmission appears on the display. The receiver confirms transmission with a sound signal.

## THERMOSTATIC MODE (AUTOMATIC)

To select the Thermostatic mode press the button. The preset temperature will show briefly then the current **room** temperature will be displayed.

### Setting the temperature:

Press and hold the button until the temperature display flashes.

Adjust the temperature by pressing the or button.

Press the button to confirm the temperature.

**i** **NOTE: If you set a temperature that is beneath the current room temperature, the fire automatically switches to PILOT (Standby).**

### Exiting Thermostatic Mode:

Press the button to exit Thermostatic mode.

Press the or button to enter Manual Mode.

Press the button to enter Program Mode.

Press the button to enter EcoFlex Mode.

## PROGRAM MODE (AUTOMATIC)

To select the Program mode press the button. The set temperature for the On time is the one set in Thermostatic Mode. Changing the thermostat temperature changes the temperature in Program mode.

### Default Settings

The On time (Thermostatic) Temperature is 21°C (70°F).  
The Off time Temperature is '-' (Pilot flame only).

### Temperature Settings

Press the button and hold until the display flashes ON and set the temperature (See Thermostatic Mode) is displayed.

Press the button or wait until OFF is displayed and the temperature flashes.

Adjust the temperature by pressing the or button.

Press the button to confirm the temperature.

**NOTE:** The On (Thermostatic) and Off set temperature is the same for each day.

### Day Setting:

ALL Flashes. Press or button to choose between ALL, SA,SU, 1, 2, 3, 4, 5, 6, 7.

Press the button to confirm.

### ALL Selected

### ON TIME SETTING (PROGRAM 1):

, 1 ON displayed, ALL is displayed shortly and **hour** flashes.

Select the **hour** by pressing the or button.

Press the button to confirm. , 1 ON displayed, ALL is displayed shortly and **minutes** flashes.

Select the **minutes** by pressing the or button.

Press the button to confirm.

### OFF TIME SETTING (PROGRAM 1):

, 1 OFF displayed, ALL is displayed shortly and **hour** flashes.

Select the **hour** by pressing the or button.

Press the button to confirm. , 1 OFF displayed, ALL is displayed shortly and **minutes** flashes.

Select the **minutes** by pressing the or button.

Press the button to confirm.

**i** **NOTE: either continue to PROGRAM 2 and set on and off times or stop programming at this point and PROGRAM 2 remains deactivated.**

**PROGRAM 1 and PROGRAM 2 use the same On (Thermostatic) and Off temperatures for ALL, SA:SU and Daily Timer (1, 2, 3, 4, 5, 6, 7). Once a new On (Thermostatic) and/or Off temperature has been set, that temperature becomes the new default setting.**

**If ALL, SA:SU or Daily Timer are programmed for PROGRAM 1 and PROGRAM 2 On and Off times these become the new default times. The batteries must be removed to clear PROGRAM 1 and 2 On and Off times and temperatures.**

### SA:SU or Daily (1, 2, 3, 4, 5, 6, 7) selected

Set On and Off time using the same procedure as 'ALL Selected' (above).

SA:SU: Set On and Off time for both Saturday and Sunday.

Daily Timer: Unique On and Off times might be set for a single day of the week for multiple days of the week or for every day of the week.

Wait to finish setting.

### Exiting Program Mode:



Press the , or button to enter Manual Mode.

Press the button to enter Thermostatic mode.

Press the button to enter EcoFlex Mode.

## ECOFLEX MODE

### Turning the EcoFlex Mode on.

Press the  button to enter EcoFlex Mode.  is displayed.

### Turning the EcoFlex Mode off.

Press the  button to exit EcoFlex Mode.  will disappear.

## DESIGNATED HIGH AND LOW FIRES

**i** **NOTE: Backlight must be on for high and low fire double click operation.**



To go to Low fire, double click the  button. LO is displayed.



Flame goes to high fire first before going to Low fire.

To go to Hi fire, double click the  button. HI is displayed.

## DUAL BURNER FUNCTION



Upon ignition Burner 1 is on and Burner 2 is in the last setting. Both sides can be activated or controlled using the Dual Burner Function.

Press and hold the  button to enter Dual Burner Function and turn on burner 2.  is displayed.

Press and hold the  button to exit Dual Burner Function leaving only burner 1 in operation.  will disappear.



## LIGHT/DIMMER OPERATION



### Turning the light on.



Press the  button to operate.  is displayed.

The lights on at preset level.



### SETTING:

Press the  button and hold until  is flashing.

To adjust the lighting between 20 % and 100% press the  or  button.

To confirm setting either press the  button or wait (  is displayed).



### Turning the light off.



Press the  button to turn off.  disappears.

**i** **NOTE: The light works independently of the Pilot flame. If you want the light on but no flame press the button to operate.**

## COUNTDOWN TIMER

### Turning the Timer on.

Press and hold the  button until  displayed, and hour flashes.

To select the **hour** press the  or  button.

To confirm press the  button. **Minutes** flash.

To select the **minutes** press the  or  button.

To confirm press the  button or wait.



### Turning the Timer off.

Press and hold the  button,  and countdown display will disappear.



**i** **At the end of countdown time period, the appliance turns off. The Countdown Timer only works in Manual, Thermostatic and EcoFlex modes. Maximum countdown time is 9 hours and 50 minutes.**

## CHILD PROOF LOCK

### Turning the Child Lock on.



Press the  and  buttons simultaneously.  will be displayed and the handset is rendered inoperable except for the Off function.

### Turning the Child Lock off.



Press the  and  buttons simultaneously to deactivate.  will disappear.



## SETTING THE TIME



Press the  and  buttons simultaneously. **Day** flashes.

Press the  or  button to select a number that corresponds with a day of the week (eg 1 = Monday, 2 = Tuesday, 3 = Wednesday, 4 = Thursday, 5 = Friday, 6 = Saturday, 7 = Sunday).

Press the  and  buttons simultaneously. **Hour** flashes.

To select hour press the  or  button.

Press the  and  buttons simultaneously. **Minutes** flash.

To select minutes press the  or  button.

To confirm press the  and  buttons simultaneously or wait.

## SETTING FAHRENHEIT OR CELSIUS

To change between °C and °F press and buttons simultaneously.

**i** **NOTE:** Choosing °F results in a 12 hour clock. Choosing °C results in a 24 hour clock.

## TROUBLESHOOTING



**IMPORTANT:** In the unlikely event that the handset fails to communicate correctly with the appliance it may be necessary to turn off the gas supply at the isolation valve until any problems can be resolved.

The gas meter and isolation valve can be located outside in a meter box, under the stairs, beneath the kitchen sink or in the garage. Whilst this list is not exhaustive, it is important to be able to identify the location of the valve in case of any gas emergency.

To turn off the gas supply, simply turn the handle so the lever is at 90 degrees to the upright gas pipe.

If you smell gas, open doors and windows and never operate any electrical switches. Immediately call the Gas Emergency Services on 0800 111 999.

## MYFIRE WI-FI KIT

This appliance can be fitted with an optional Wi-Fi kit which can allow operation from a tablet or smart device: Gazco part No. 999-055. Contact your Gazco retailer for more information.

## MYFIRE WI-FI TROUBLESHOOTING

The MyFire Wi-Fi box must be wired according to the MyFire set up diagram and connected to the receiver, which is in turn connected to the mains power.

Ensure the device is running the most up to date operating system as older models may not be compatible with the MyFire App.

After 30 seconds the MyFire Box goes into Access Point Mode (Green LED flashes). See MyFire App instructions supplied and configure the router.

The following things can affect the Wi-Fi signal on the appliance:

- Multiple users on the same Wi-Fi channel may interfere with the data transfer. Press the reset button on the MyFire Wi-Fi box for 1 second to change the current channel.
- If the MyFire Wi-Fi box is not connected to the receiver or is not used it will leave Access Point Mode after 24 hours.
- If there are any changes to the home network then the MyFire Wi-Fi set up must be repeated.

Quick Reference Table - for LED.

LED INDICATOR FOR MYFIRE WI-FI BOX			
LABEL	LED		STATUS
Power	Blue	On	Power On
		Off	Power Off
WLAN	Green	On	Connected to home network (Wi-Fi Router)
		Off	Not connected to home network (Wi-Fi Router)
		Flashing	MyFire Wi-Fi Box in Access Point Mode
Receiver	Blue	On	Receiver connected
		Off	No receiver connected or connection lost
All LEDs		Flashing	Internal Configuration

It may be necessary to reset the MyFire Wi-Fi box using a paperclip or similar. The table below shows the length of time required for each reset and the confirmation signals.

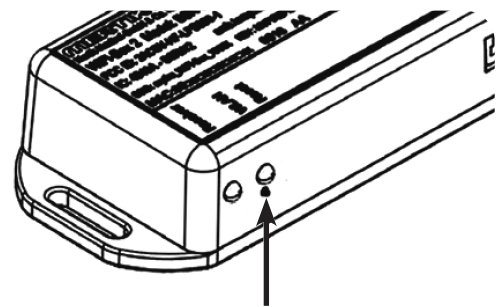

Press Reset Button	LED Status Blue Power LED	Function
1 Sec	Continuously flashes every ½ second	Activates Access Point Mode for 10mins (connect MyFire Wi-Fi module to home network). Simultaneously the Wi-Fi channel changes.
5 Secs	Two rapid flashes every 1 second	System Reset.
10 Secs	Flashes every 100 milliseconds (Continuous)	Restore factory firmware (MyFire Wi-Fi module will set to default after reboot); takes up to 2 minutes.
20 Secs	Flashes every 50 milliseconds (Continuous)	Restores factory firmware and erases all data not locked. (MyFire Wi-Fi module will set to default after reboot); takes up to 2 minutes.

## CLEANING THE APPLIANCE

From time to time it may be necessary to remove build up of debris and soot from the logs.

Make sure the appliance and surrounds are cool before cleaning.

Remove the side trims and lower trim from the appliance.

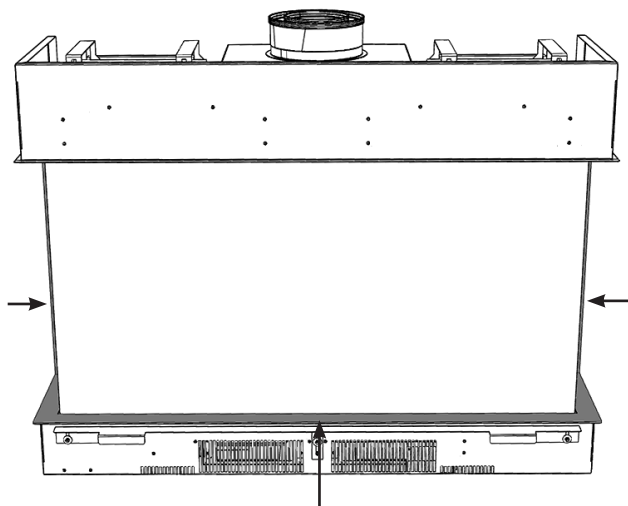

Loosen the 7 screws securing the pivot brackets (do not remove).

Using the tool provided turn the 7 Pivot Brackets (4 Top, 3 Bottom) 90° anti-clockwise to the open position.

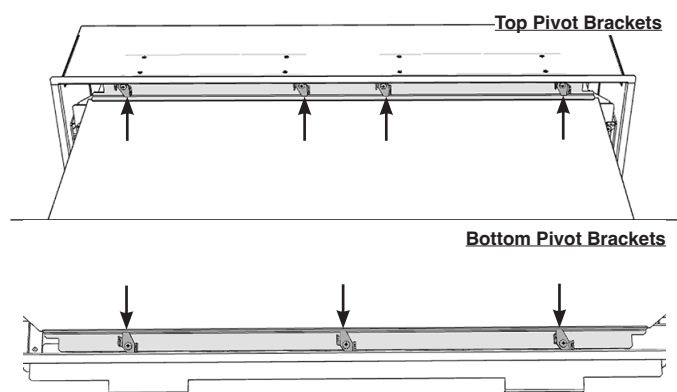

With the Cam Lock Brackets open, slide the top and bottom support brackets away from the Front Glass.

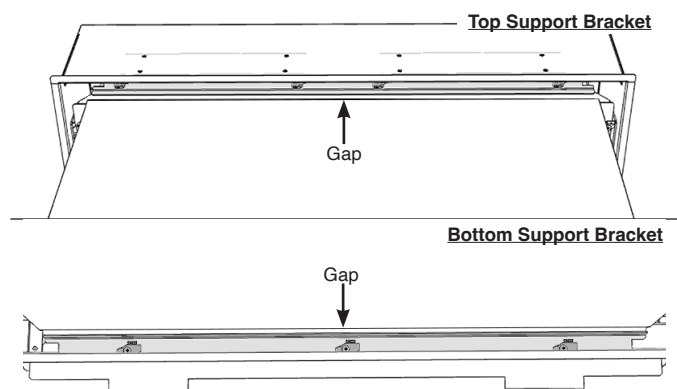

The Front Glass can now be removed. Carefully move the front glass into the gap, then lift and manoeuvre the bottom outwards to remove.

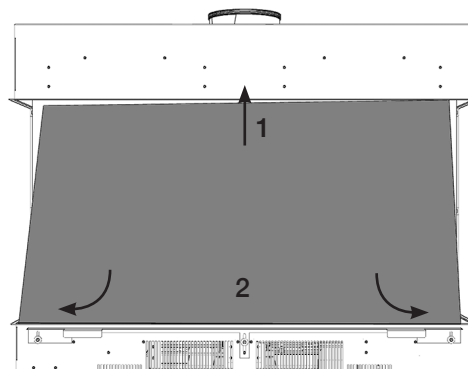

**The side glass does not need to be removed to clean the appliance. It is recommended to leave the Side Glass in situ unless absolutely necessary.**

Should the logs require cleaning, lightly brush with a soft brush. Any large pieces of debris may be removed by hand.

**DO NOT USE A VACUUM CLEANER.**

Use a damp cloth to clean the outer casing of the appliance.

To clean the glass surface use a non abrasive glass cleaner and soft cloth.

The glass panel must be refitted to the appliance following cleaning or servicing.

To replace the glass panel, replace in reverse order.



**UNDER NO CIRCUMSTANCES SHOULD THE APPLIANCE BE USED IF ANY OF THE GLASS PANELS ARE LOOSE, DAMAGED, OR MISSING.**

Replace the lower and side trim.

**ENSURE THAT ALL GLASS PANELS ARE FLUSH AND THAT THERE ARE NO GAPS BETWEEN PANELS. NEVER OPERATE THE APPLIANCE WHEN THE GLASS PANEL IS REMOVED OR BROKEN.**

## FLAME FAILURE DEVICE

This is a safety feature incorporated on this appliance which automatically switches off the gas supply if the pilot goes out and fails to heat the thermocouple.

**IF THIS OCCURS DO NOT ATTEMPT TO RELIGHT THE APPLIANCE FOR 3 MINUTES.**

## RUNNING IN

During initial use of a new Gazco appliance a strong odour will be encountered as various surface coatings become hot for the first time. Although these odours are harmless it is recommended that the appliance is operated on maximum for 4 to 8 hours in order to fully burn off these coatings. After this period the odours should then disappear.

If the odours persists, please contact your installer for advice.

During the first few hours of burning there may be discolouration of the flames. This will also disappear after a short period of use.

## SERVICING AND SUPPORT



### Servicing and Support

To keep your appliance looking and performing at its best, it must be serviced annually. This service must be undertaken by a suitably qualified individual and your retailer can organise this for you. Alternatively, Gazco offer a manufacturers premium service with our friendly team of qualified engineers which can be booked at [www.gazco.com/support](http://www.gazco.com/support)

In all correspondence always quote the Model number and the Serial number which may be found on the Commissioning Checklist (Page 3).

## INSTALLATION DETAILS

Your installer should have completed the commissioning sheet at the front of this book. This records the essential installation details of the appliance. In all correspondence always quote the Model number and Serial number.

## HOT SURFACES

Parts of this appliance become hot during normal use.

Regard all parts of the appliance as a working surface.

Provide a suitable fire guard to protect young children and the infirm.

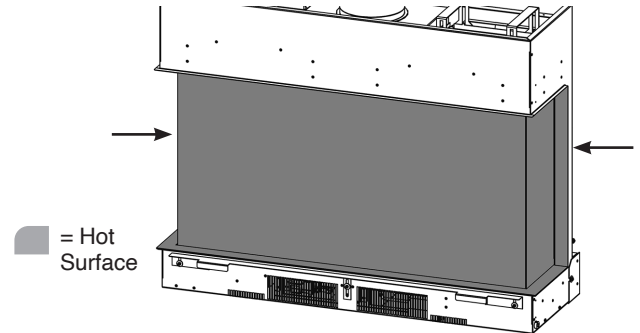

## APPLIANCE WILL NOT LIGHT

If you cannot light the appliance:

Check and change the batteries in the remote handset.

Consult your Gazco retailer or installer if the appliance still does not light.

## CO ALARMS

Building regulations require that whenever a new or replacement fixed gas burning appliance is installed in a dwelling, a carbon monoxide alarm complying with BS EN 50291-1 (latest edition) must be fitted in the same room as the appliance. Further guidance and recommendations on the installation of carbon monoxide alarms is available in BS EN 50292 (latest edition) and from manufacturers' instructions.

**Provision of an alarm must not be considered a substitute for either installing the appliance correctly or ensuring regular servicing and maintenance of the appliance.**

## INSTALLATION INSTRUCTIONS

### APPLIANCE LOCATION

This appliance **must** only be fitted into a studwork installation.

This appliance must not be installed in a room that contains a bath or shower.

Combustible parts of the studwork must not be any closer than the minimum dimensions shown in the diagrams. NOTE: These dimensions must be maintained even if the combustible materials is protected by non-combustible linings.

Do not pack the void around or above the appliance with insulation materials such as mineral wool.

### VENTILATION

The installation of this product requires no additional ventilation modifications to the building.

However, it will be necessary to ensure the housing for the appliance has vents provided to allow air to circulate and prevent overheating.

This can be done in the form of an installation with a 'Shadow Gap' at the top of the void or with purpose built vents.

If the void is sealed to the floor and/or ceiling is necessary to fit a low vent with a minimum free area of 150cm<sup>2</sup> and a high vent of 400cm<sup>2</sup>.

Gazco supplies the following vent options:

CENTRAL	POSITION	COLOUR	CODE
600 x 400 x 60mm	LH Corner Open	White	991-609
600 x 400 x 60mm	RH Corner Open	White	991-620
800 x 60mm	Central	White	991-643

A removable access hatch must be left in the side of the chimney breast for future servicing and inspection of the appliance.

Build the studwork chimney breast to the desired size. Ensure that the clearances to combustible materials is maintained.

### SAFETY PRECAUTIONS

For your own and other's safety, you must install this appliance according to local and national codes of practice. Failure to install the appliance correctly could lead to prosecution. **Read these instructions before installing and using this appliance.**

These instructions must be left intact with the user.

Do not attempt to burn rubbish on this appliance.

Keep all plastic bags away from young children.

Do not place any object on or near to the appliance and allow adequate clearance above the appliance.

**IF THE APPLIANCE IS EXTINGUISHED OR GOES OUT IN USE, WAIT 3 MINUTES BEFORE ATTEMPTING TO RELIGHT THE APPLIANCE.**



**IMPORTANT: REFER TO DATA BADGE AND TECHNICAL SPECIFICATION AT THE FRONT OF THE MANUAL TO ENSURE THE APPLIANCE IS CORRECTLY ADJUSTED FOR THE GAS TYPE AND CATEGORY APPLICABLE IN THE COUNTRY OF USE.**

### UNPACKING

Remove the appliance from its packaging, and check that it is complete and undamaged.

Put the loose ceramic parts to one side so that they are not damaged during installation.

## FLUE & CHIMNEY REQUIREMENTS

**Note: This appliance must only be installed with the flue supplied.**

The following: must be adhered to:

The flue must be sited in accordance with BS5440: Part 1 (latest edition).

Fit a guard to protect people from any terminal less than 2 metres above any access such as level ground, a balcony or above a flat roof. All vertical and horizontal flues must be securely fixed and fire precautions followed in accordance with local and national codes of practice.

Two types of flue terminals are available, horizontal and vertical.

To measure for a horizontal terminal decide on the terminal position.

Measure the height from the top of the appliance to the centre of the required outlet. For minimum and maximum flue dimensions see relevant sections.

Allow enough room either above or to the side of the appliance to assemble the flue on top.

Assemble a horizontal flue in the following order:

- Vertical section
- 90° elbow
- Horizontal plus terminal

Support the opening of a masonry installation with a lintel.

Only the horizontal terminal section can be reduced in size.

## TIMBER FRAMED BUILDINGS

It will be necessary to provide additional clearance when the flue passes through a wall containing any combustible materials so as to prevent a fire hazard.

The hole through which the flue will pass, must have a steel sleeve which is positioned so that an air gap of at least 25mm is maintained between the outer surface of the flue, and any part of the sleeve.

For further guidance on the installation of gas appliances in timber framed buildings, contact your local buildings control authority.

## GAS SUPPLY

**This appliance is intended for use on a gas installation with a governed meter.**

Make sure local distribution conditions (identification of the type of gas and pressure) and the adjustment of the appliance are compatible before installation.

Ensure the gas supply delivers the required amount of gas and is in accordance with the rules in force.

Soft copper tubing can be used on the installation and soft soldered joints outside the appliance.

A factory fitted isolation device is part of the inlet connection; no further isolation device is required.

All supply gas pipes must be purged of any debris that may have entered prior to connection to the appliance.

The gas supply enters through the Silicone Panel located on the LEFT-HAND side of the outer box BASE. Slit with a sharp knife prior to passing the supply pipe through.

The gas supply must be installed in a way that does not restrict the removal of the appliance for servicing and inspection.

TECHNICAL SPECIFICATION

DIMENSIONS (mm)

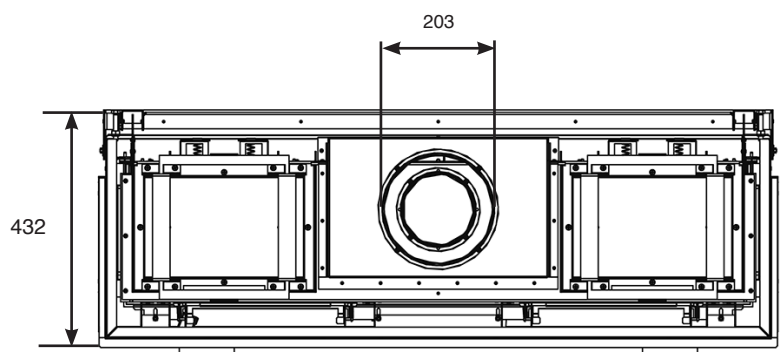
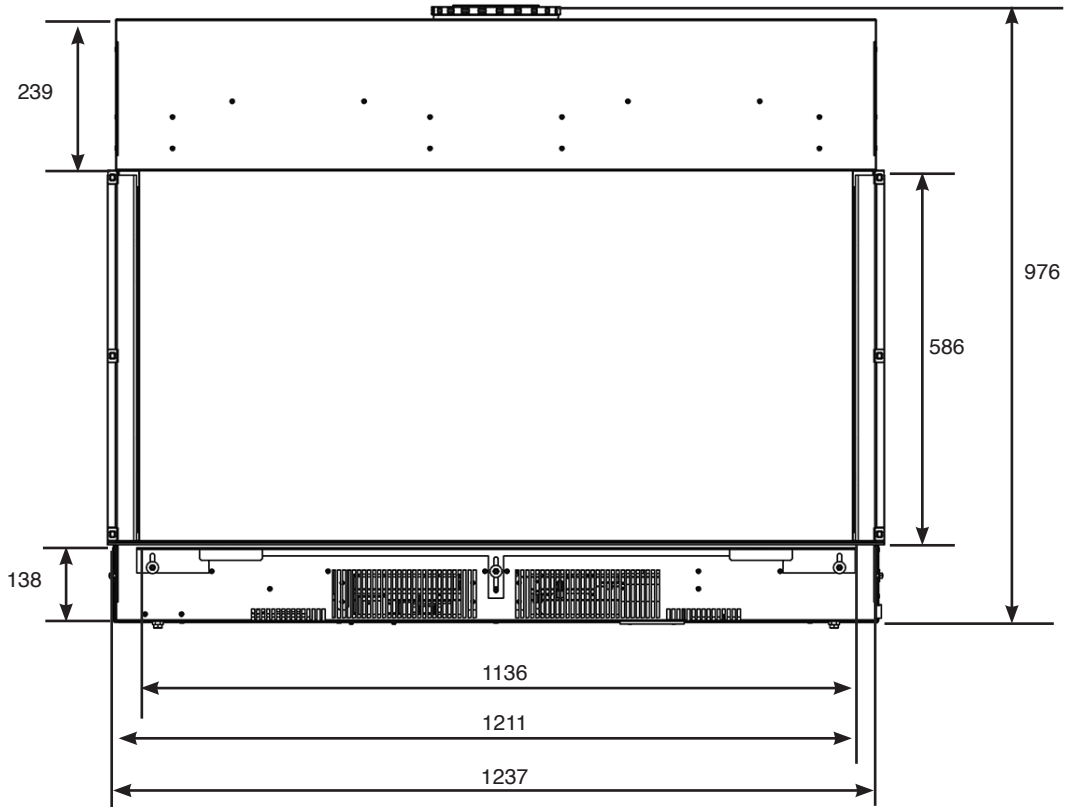

## TECHNICAL SPECIFICATION

Covering the following models:

NAT GAS	LPG
191-014	191-405

MODEL	APP CAT.	GAS TYPE	WORKING PRESSURE	GAS RATE M <sup>3</sup> /H	INPUT KW (GROSS)		COUNTRY
					HIGH	LOW	
Reflex 105	I <sub>2</sub> H	Nat Gas G20	19mbar	1.191	12.5	5.9	GB, IE
Reflex 105	I <sub>3+</sub>	Propane G31	36mbar	0.508	13.5	5.6	
		Butane G30	28mbar	0.386			
<b>Efficiency Class 1 - 89% / NO<sub>x</sub> Class 4</b>							
Flue Outlet Size Ø 130mm							
Flue Inlet Size Ø 200mm							
Gas Inlet Connection Size Ø 8mm							

Power Supply: A 230V +/- 10% - 50Hz  
 Maximum power consumption: 9 Watts  
 Operating Temperature: 0°C - 40°C

### THIS APPLIANCE MUST BE EARTHED

A 2 metre lead with plug containing a 3 amp fuse is supplied. Only use a 3 amp fuse with this appliance.

**i** The net efficiency of this appliance has been measured as specified in EN613:2001 and the result after conversion to gross using the appropriate factor from Table E4 of SAP 2012 is 82%. The test data has been certified by Kiwa Nederland BV. The gross efficiency value may be used in the UK Government's Standard Assessment Procedure (SAP) for energy rating of dwellings.

TECHNICAL SPECIFICATION

INJECTOR TABLE

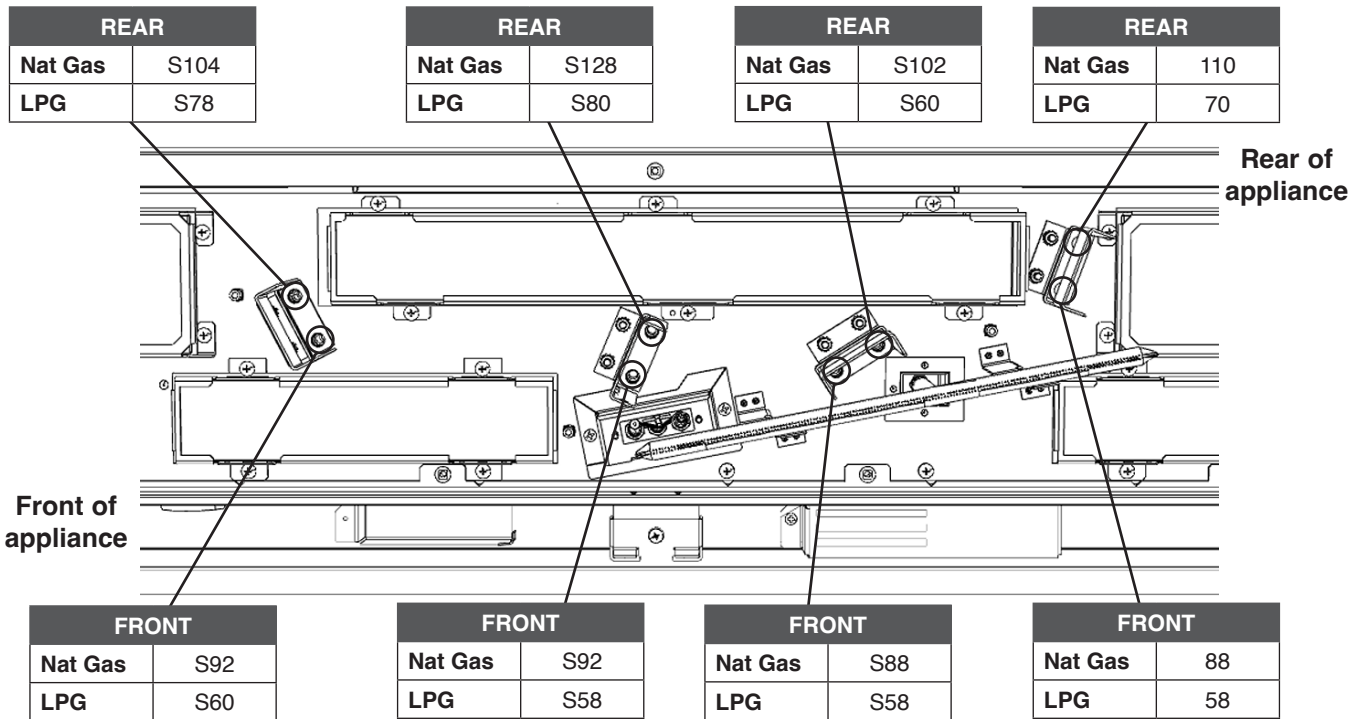

AERATION TABLE

NOTE: Aeration plates are on each leg of the burners. These holes are different sizes at the Front and Back for each individual leg.

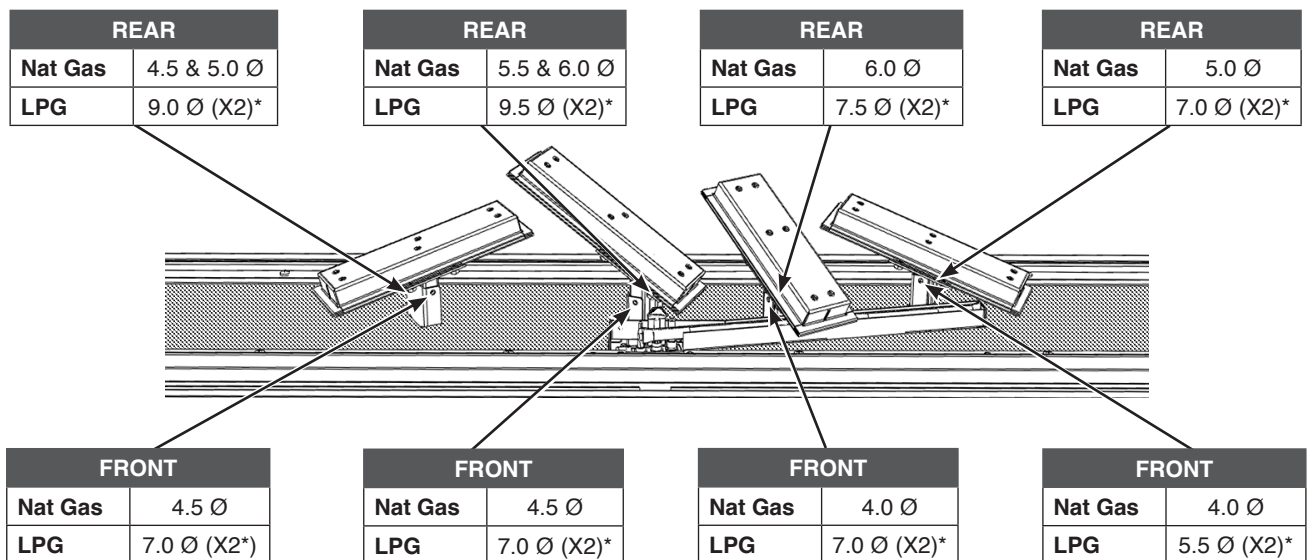

\*(X2) indicates that a hole is necessary in each side of the leg.

## TECHNICAL SPECIFICATION

### RESTRICTOR TABLES

#### RESTRICTOR REQUIREMENT - VERTICAL & HORIZONTAL FLUE SPECIFICATION

REFLEX 105			
Vertical flue height from top of appliance	Horizontal length	Restrictor size	
		NG	LPG
200mm - 1499mm	up to 3500mm	-	-
1500mm - 1999mm	up to 6000mm	90	-
2000mm - 3000mm	up to 6000mm	85	90

#### TOP EXIT - VERTICAL ONLY INCLUDING OFFSET (8" WITH 6" ADAPTER)

Vertical flue height from top of appliance	Restrictor size	
	NG	LPG
1500mm - 2999mm	80mm	90mm
3000mm - 5999mm	75mm	80mm
6000mm - 10000mm	70mm	70mm

This appliance has been certified for use in countries other than those stated. To install this appliance in these countries, it is essential to obtain the translated instructions and in some cases the appliance will require modification. Contact Gazco for further information.

#### PACKING CHECKLIST

QTY. DESCRIPTION	FIXING KIT CONTAINING
1 x Cassette and burner assembly	1 x Instruction manual
1 x Set of lining panels	1 x Quick Start Guide
1 x Log set (5 logs)	1 x Handset
3 x Large Embers	2 x AAA cell batteries
1 x Pilot Ember	2 x Rear Upper Liner
1 x Small Embers	Retaining Bracket
1 x Shale Effect pack	2 x Rear Lower Liner
1 x Amber Effect pack	Retaining Bracket
	6 x M8 Anchor bolts
	2 x No.8 Self Tapping Screws
	1 x Burner Infill
	1 x Hand Tool

WIRING DIAGRAM

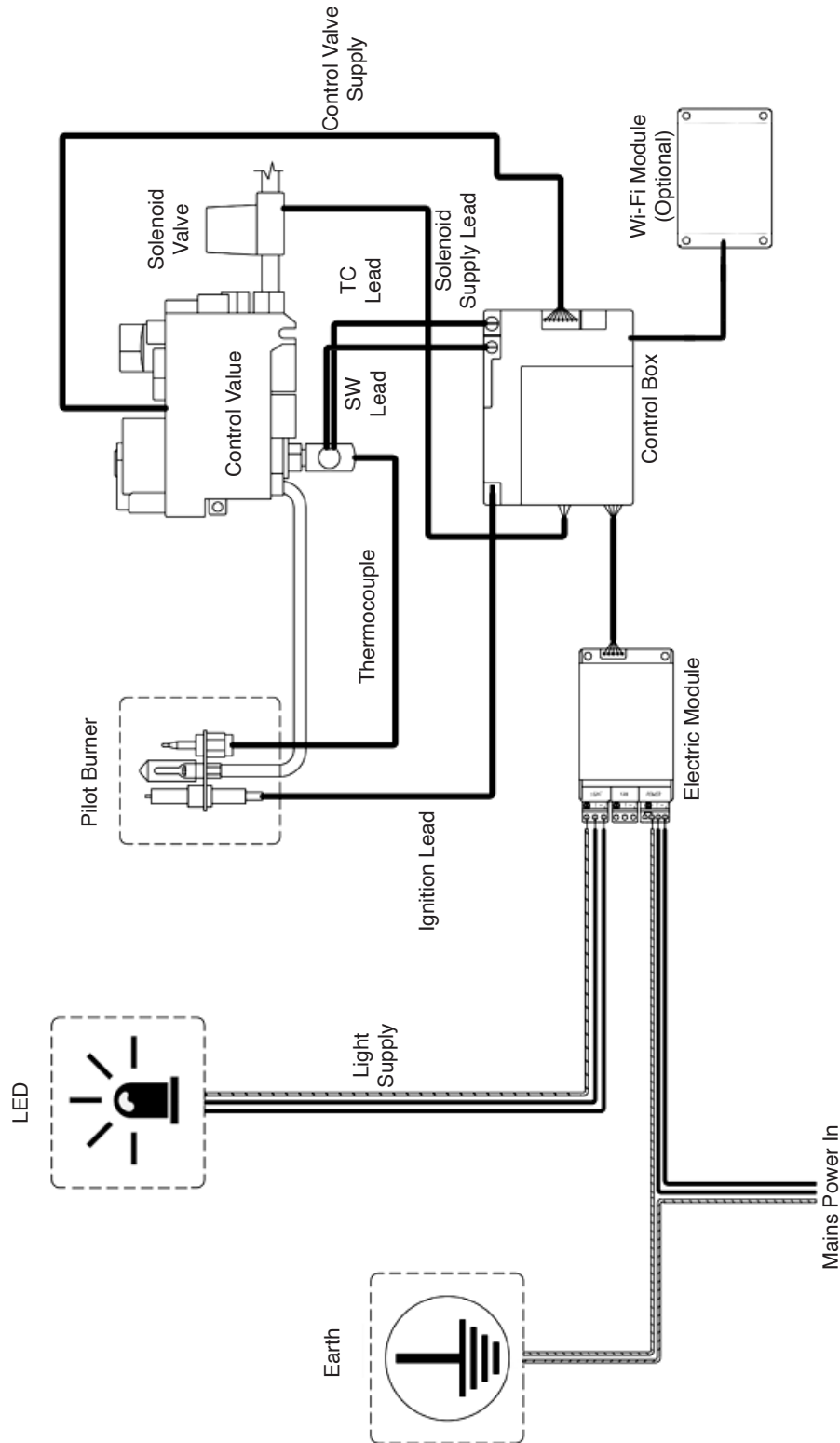

## FLUE OPTIONS



All flue installations must be constructed in accordance with the rules in force.  
UK - Building Regulations: Approved Document J.

### 8" TOP FLUE UP AND OUT KIT (999-227)



**NOTE:** This product is designed for and requires an 8" flue system. It is essential when ordering additional parts to consult table 1 (page 19) for the relevant part numbers.

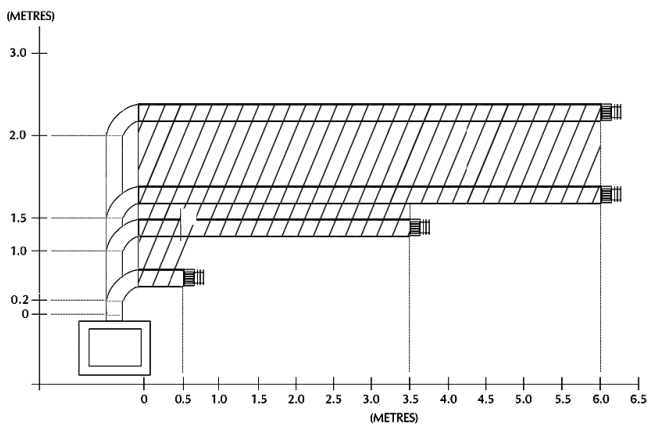

Start of bend to centre line of horizontal flue 198mm. Centre line of vertical flue to end of bend 248mm.

Vertical from the top of the appliance then horizontally out, see Diagram. The basic kit comprises:

- 1 x Horizontal Rear Exit Flue Terminal
- 1 x 200mm 8" Flue Pipe
- 1 x 90 Degree Elbow
- 1 x Wall Plate
- 4 x Fixing Screw
- 4 x Rawl Plug
- 1 x 85mm Restrictor Plate
- 1 x 90mm Restrictor Plate
- 1 x Horizontal Rear Exit Terminal Guard

This kit provides the minimum materials. Extra lengths can be added to the vertical and horizontal sections; see table 1 - 8".

Refer to Installation Instructions, Technical Specification on page 7 to identify when to use a restrictor.

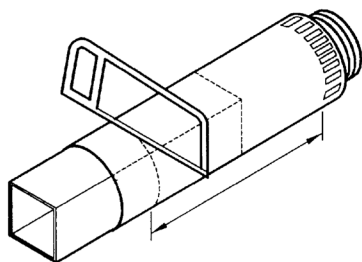

Decide on the terminal position.

Measure the height from the finished hearth level/ base of the appliance to the centre of the required hole.

A masonry installation requires the addition of a suitable lintel to support the opening. Refer to Installation Instructions, Technical Information for details of the flue length.

NOTE - Carefully consider:

- a) Terminal positions
- b) Flue supports
- c) Weatherproofing
- d) Fire precautions

For all the above options, you must conform to local and national codes of practice.

Use only Gazco supplied flue on this appliance.

A guard (supplied) must be fitted to any terminal less than 2 metres above any access such as level ground, a balcony or above a flat roof.

### TOP FLUE UP AND OUT WITH ADDITIONAL BEND

Any additional bend may be used on the horizontal section (either 45° or 90°), but the overall horizontal flue run will be reduced.

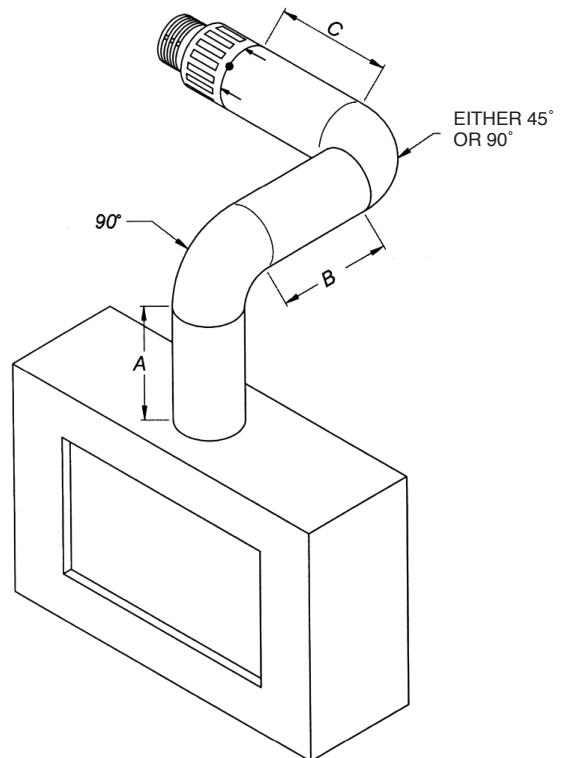

When A = 1.5 to 2.0 metres B + C = 5.0 metres maximum

## TOP FLUE VERTICAL KIT (999-352)



**NOTE:** This product is designed for and requires an 6" flue system. It is essential when ordering additional parts to consult table 2 for the relevant part numbers.

This flue is vertical from the top of the appliance, see Diagram. A minimum vertical rise of 1.5m to a maximum of 10m.

The basic kit comprises:

- 1 x 8" to 6" Adapter
- 1 x 500mm Length
- 1 x 1m Terminal Length
- 1 x Wall Plate
- 1 x 60mm Restrictor Plate
- 1 x 70mm Restrictor Plate
- 1 x 75mm Restrictor Plate
- 1 x 80mm Restrictor Plate
- 1 x 90mm Restrictor Plate
- 4 x Fixing Screw
- 4 x Rawl Plug

Extra lengths may be added from table 2 in Section 3.

Fit the adapter prior to connecting the flue pipe.

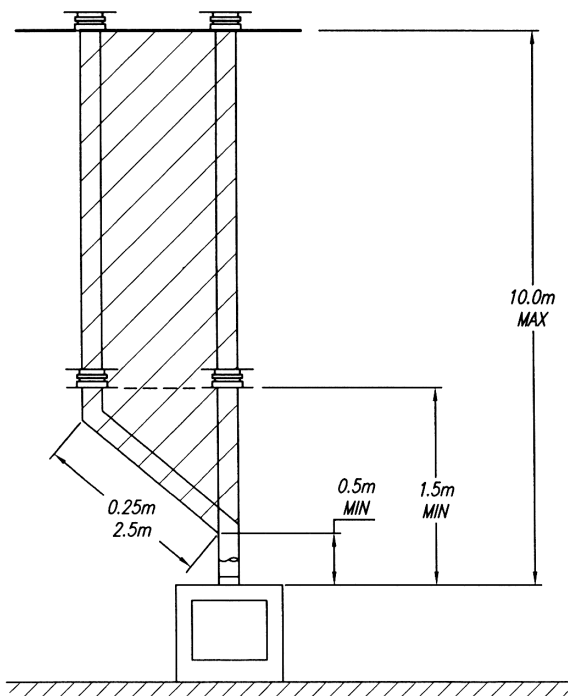

### FLUE ADAPTER

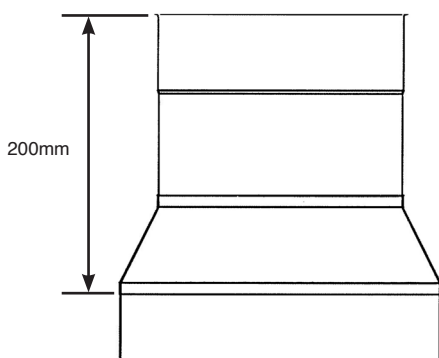

## TOP FLUE VERTICAL OFFSET KIT (8530/8530AN)

Used with kit 8524. A minimum rise of 500mm is required to the first bend.

## OPTIONAL EXTRA FLUE LENGTHS AND BENDS

TABLE 1 - 8"		
NOMINAL LENGTH	ACTUAL LENGTH	STAINLESS FINISH
200mm	140mm	999-113
500mm	440mm	999-132
1000mm	940mm	999-177
Adjustable Length		999-255

TABLE 2 - 6"		
NOMINAL LENGTH	ACTUAL LENGTH	STAINLESS FINISH
200mm*	140mm*	8527
500mm*	440mm*	8528
1000mm*	940mm*	8529

\*Not including adapter dimensions

**NOTE:** The following areas need careful consideration.

- a) Terminal positions
- b) Flue supports
- c) Weatherproofing
- d) Fire precautions

For all the above options, local and national codes of practice must be adhered to.



**IMPORTANT:**  
1M VERTICAL, TERMINAL AND STRAIGHT FLUE LENGTHS MUST NOT BE CUT!

## MOUNTING BRACKET

### REMOVING THE MOUNTING BRACKET



This appliance weighs 110Kg. The manufacturer has designed this appliance to attach to a masonry wall and all fixings supplied reflect this. However if desired it is possible to locate the Reflex on a non-combustible studwork wall providing it is constructed to give adequate load bearing support. If intending to install the appliance on a studwork wall it is essential that the battens are located across the fixing areas of the wall mounting bracket.

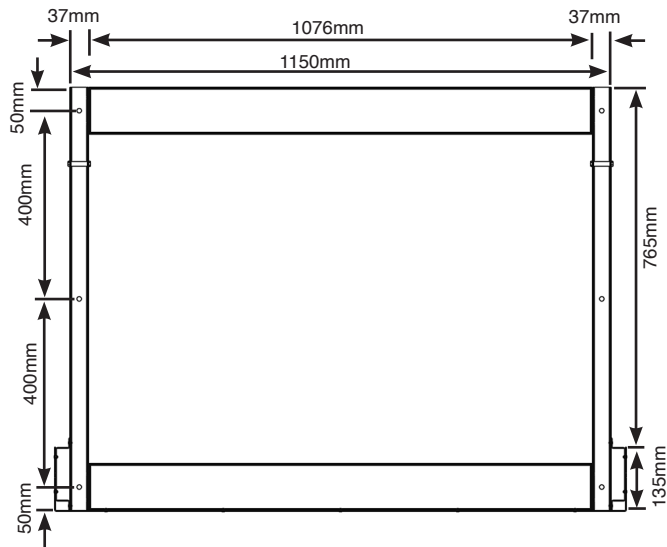
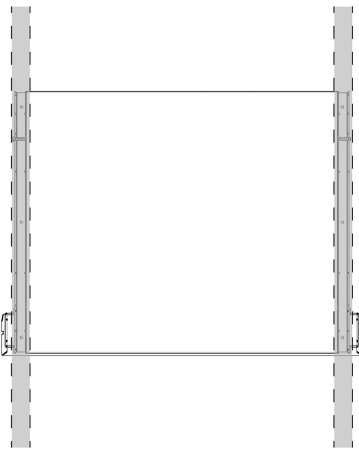

The fixing points must be through the timber stud and not plasterboard. Use appropriate fixings.  
**DO NOT** attach solely to a plasterboard wall.

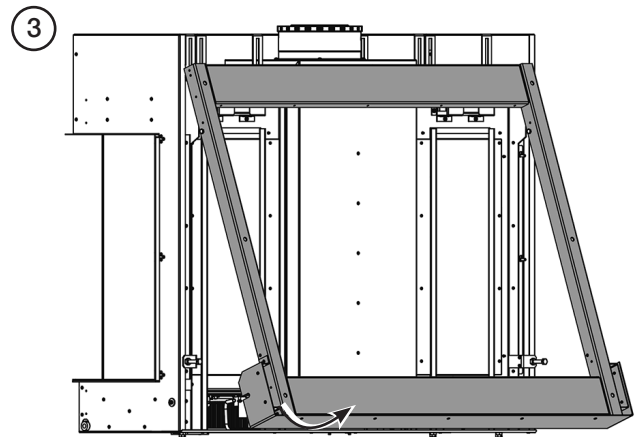
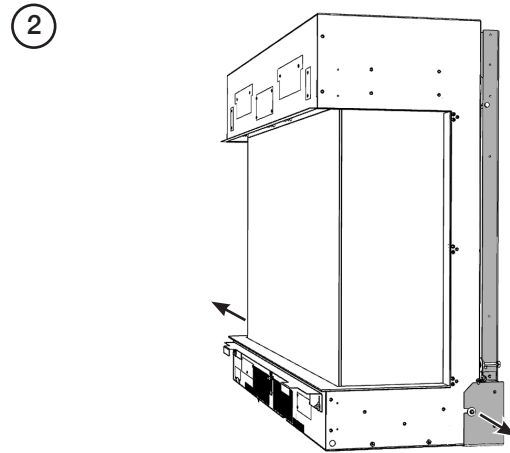
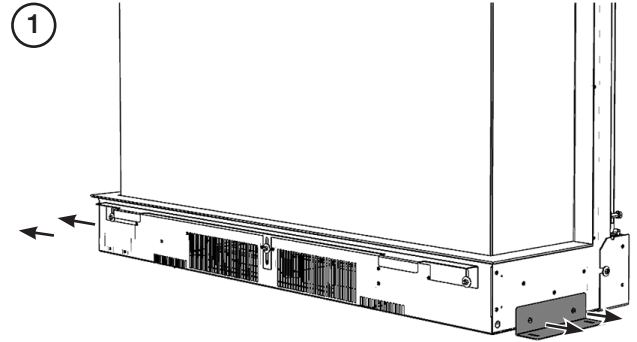

## MOUNTING BRACKET CLEARANCES

### FLOOR MOUNTED

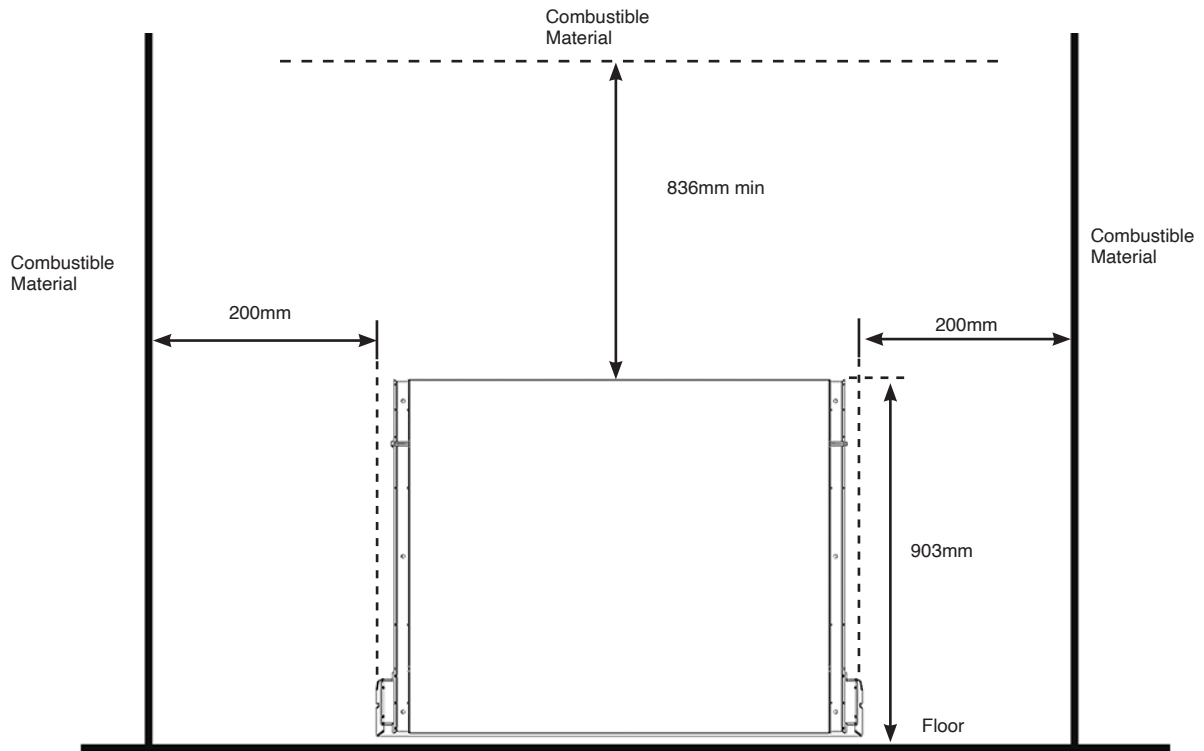

### WALL MOUNTED

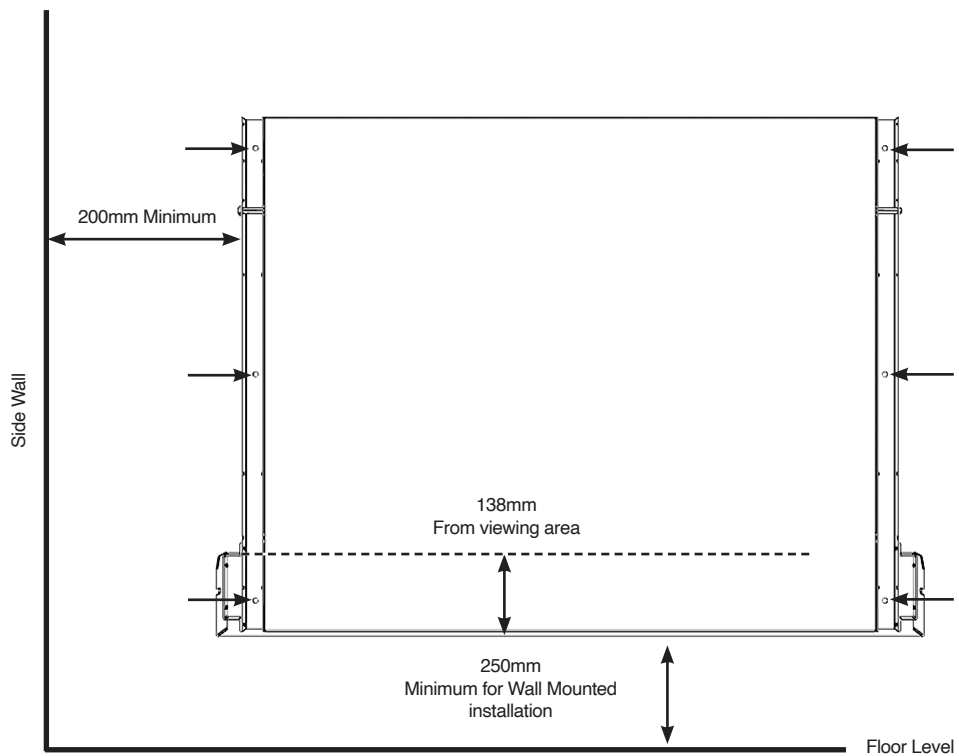

PRE-INSTALLATION

REMOVING THE GLASS

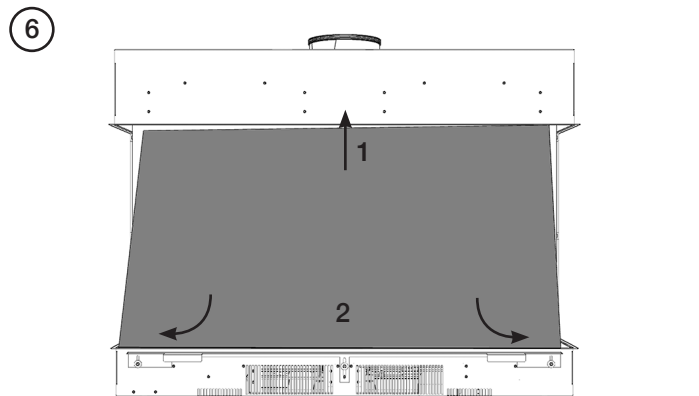
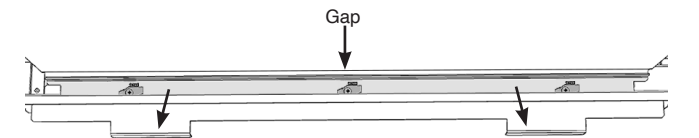
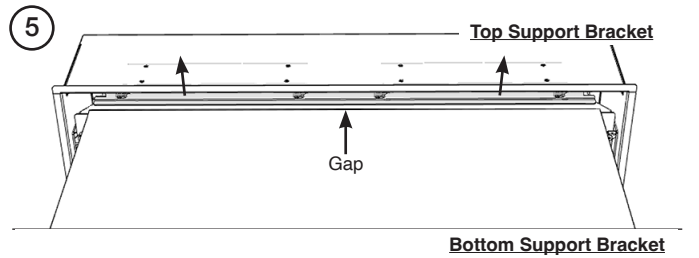
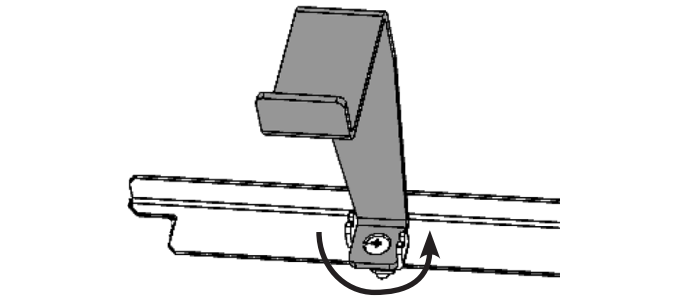
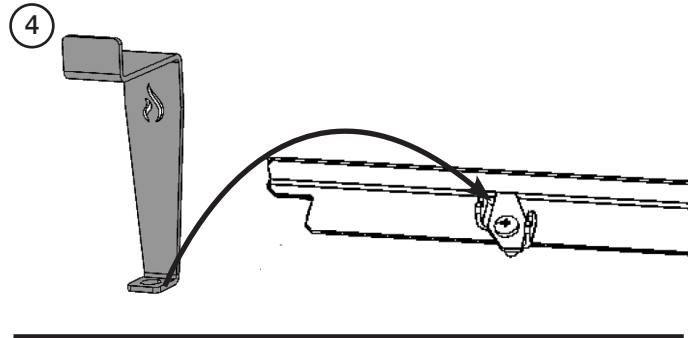
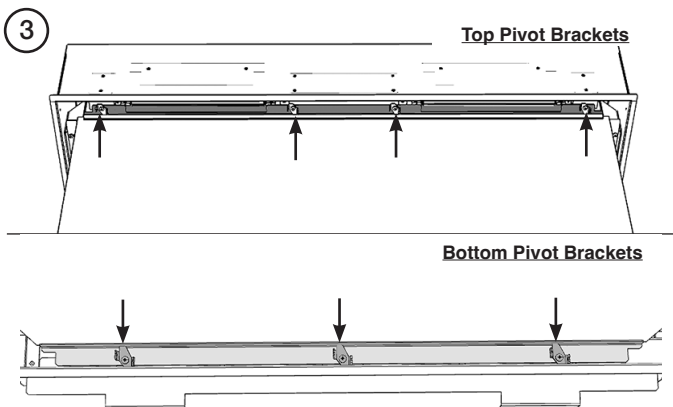
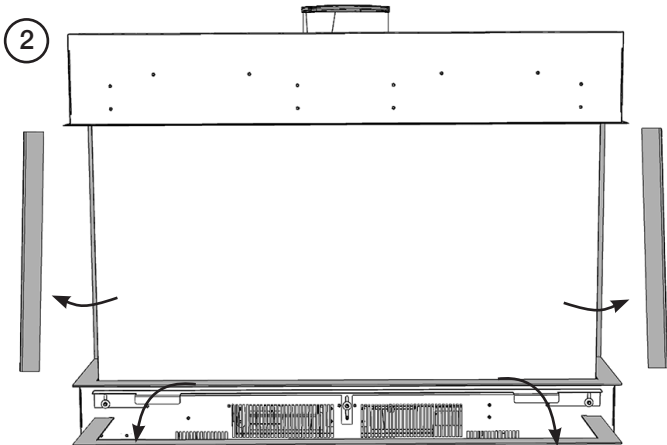
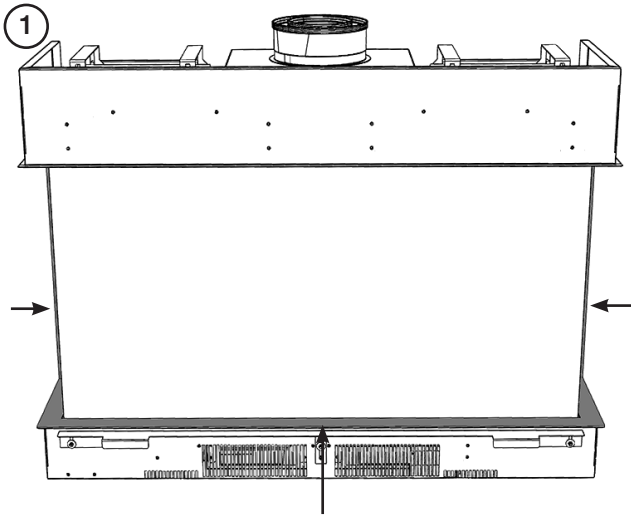

**i** The side glass does not need to be removed to install the appliance. It is recommended to leave the Side Glass in situ unless absolutely necessary.

## REMOVING THE MAIN CONTROL ASSEMBLY

The Main Control Assembly will need to be removed to install the gas supply.

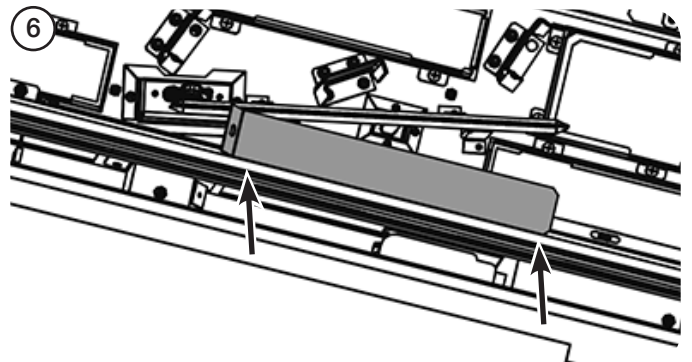
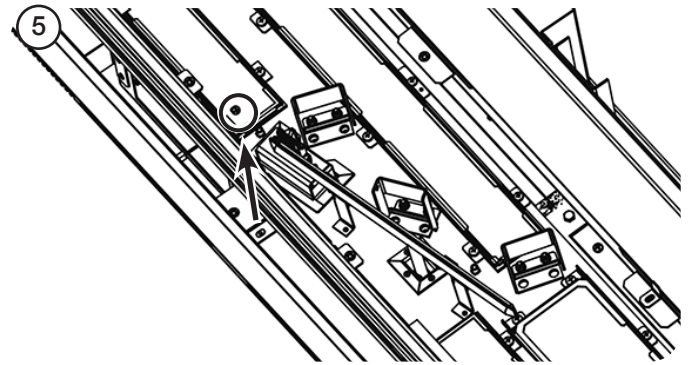
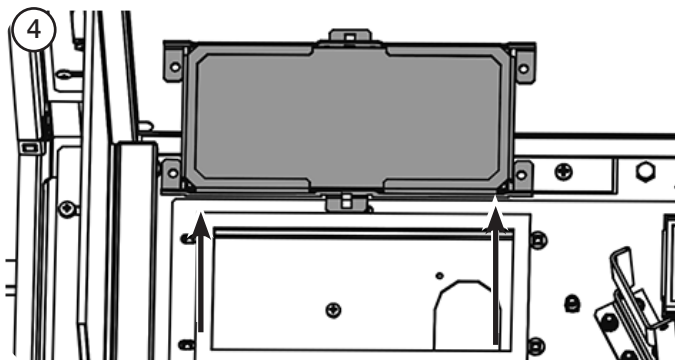
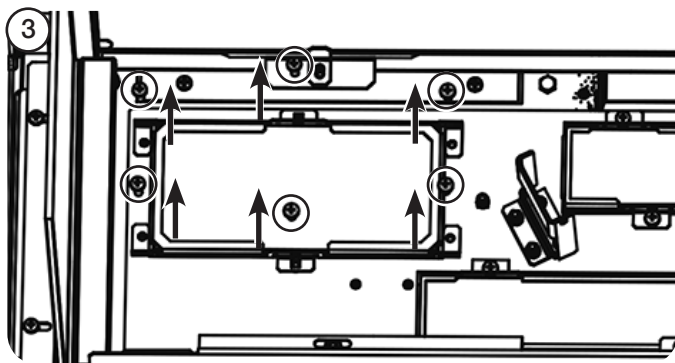
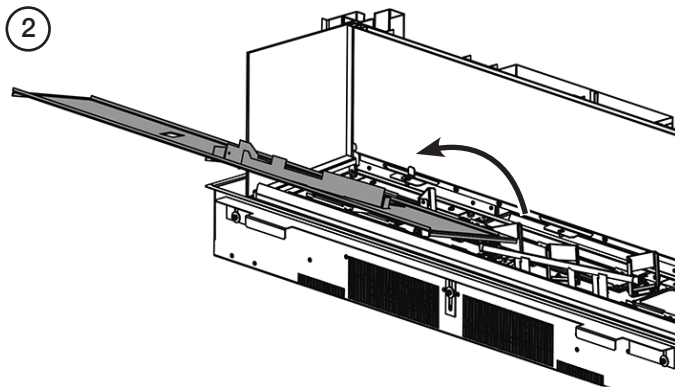
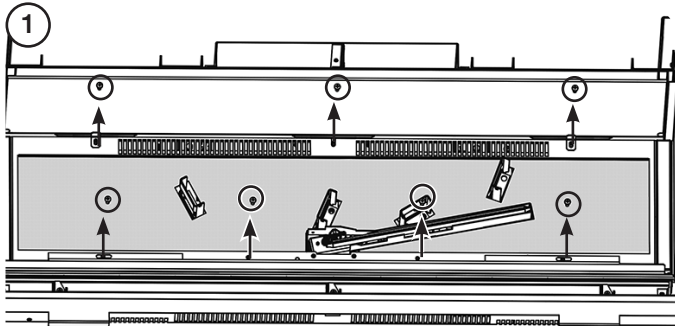

Disconnect the Mains Lead Plug, the LED leads and the receiver lead from the Module and the Wi-Fi box (if installed).  
**DO NOT REMOVE THE WIRES FROM THE PLUG.**

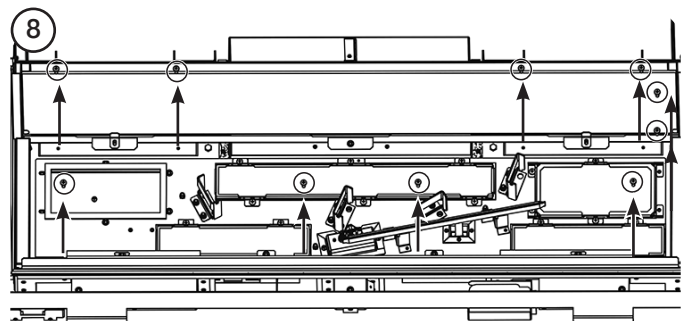
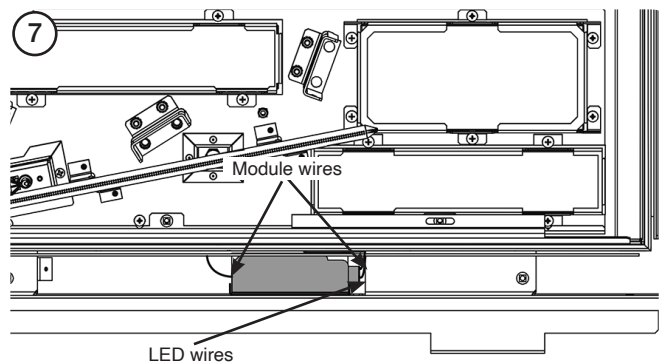

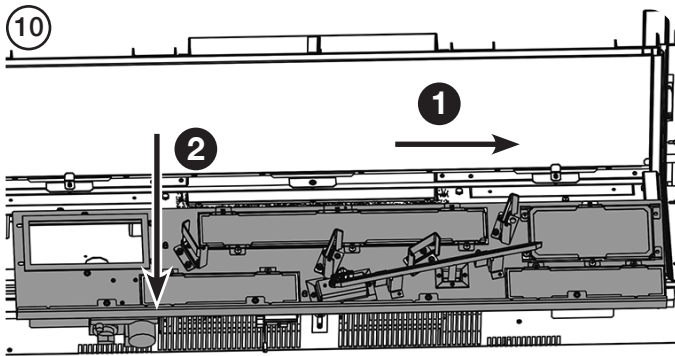
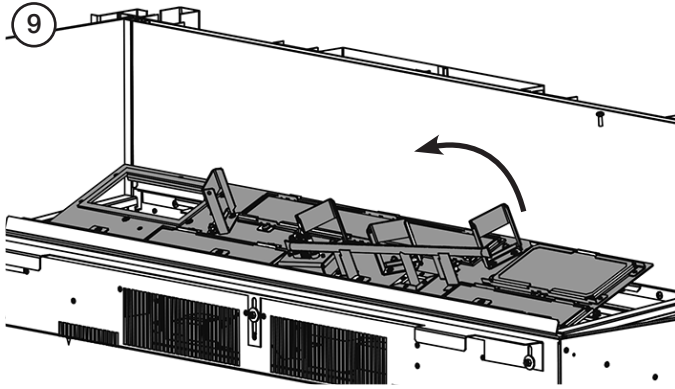

NOTE: Take care not to catch any loose wiring previously disconnected against the front edge of the firebox.

The gas supply enters through the Silicone Panel located on the left-hand side of the outer box base; this will need to be slit with a sharp knife prior to passing the supply pipe through.

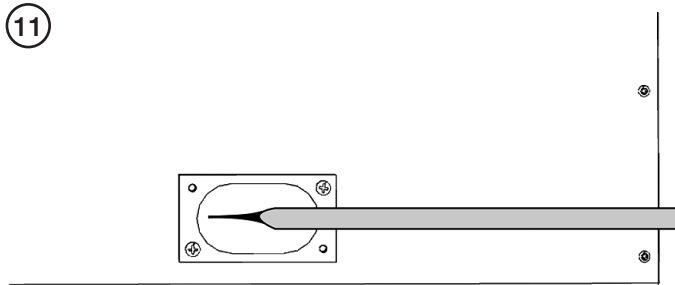

The Isolation Elbow needs to be attached to the gas pipe before installation, see diagram for location.

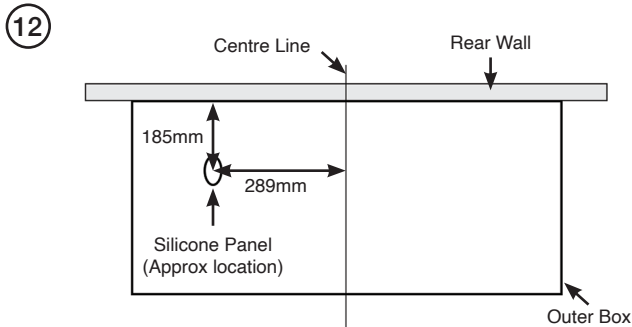

The appliance stands off the wall by 55mm. It will be necessary to build a studwork enclosure to house the mounting bracket and separate enclosures for the upper and lower faces of the appliance.



**WARNING:** This appliance weighs 108Kg. The manufacturer has designed this appliance to attach to a masonry wall and all fixings supplied reflect this. If siting on a studwork wall, the fixing points must be through the timber stud and not plasterboard. Use appropriate fixings. **DO NOT** attach solely to a plasterboard wall.



The fixings supplied for the Wall Mounted Kit are R-RBL Rawlbolts and should be fitted in the method described below.

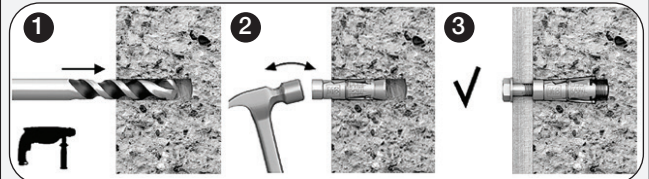

Ensure a minimum substrate thickness of 100mm.

1. Drill a hole - Diameter: 14mm x Depth: 65mm.  
Note: When fixing into brickwork, mortar joints should be avoided  
Remove debris and thoroughly clean hole with brush and pump
2. Remove pre-assembled bolt and washer. Insert shield into hole and tap home with hammer until flush with surface
3. Insert bolt with washer through fixture into the shield  
Tighten to 15Nm torque.

Position the wall mounting bracket in the required location.



If required, use the two adjustment bolts at the rear of the appliance to alter the vertical position of the fire.

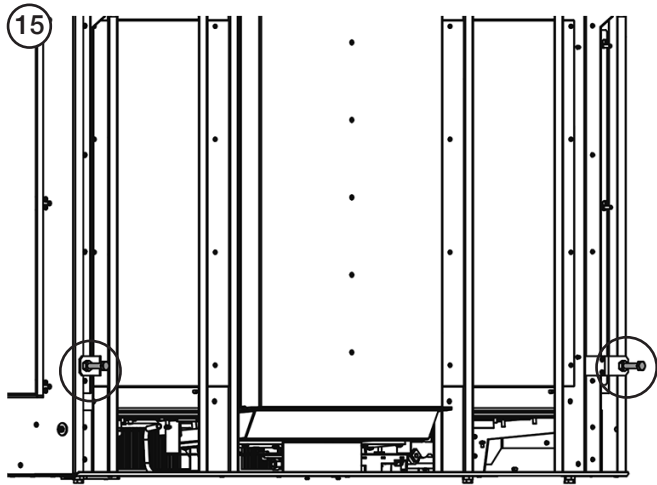

Wall Bracket removed for clarity

Run the mains power lead out of the right side of the appliance.

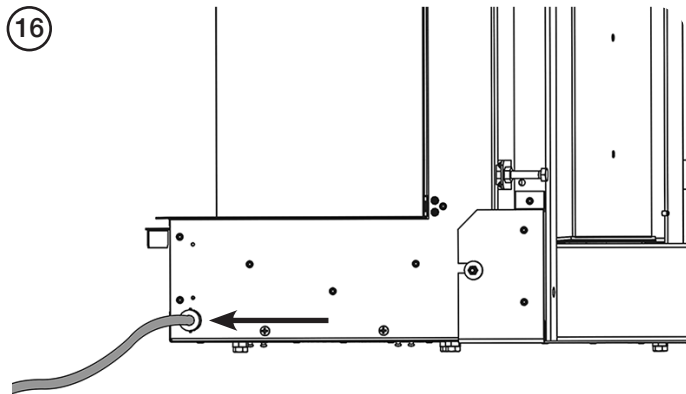

Wall Bracket removed for clarity

Once satisfied with the position of the appliance, tighten the 2 nuts on either side of the fire.

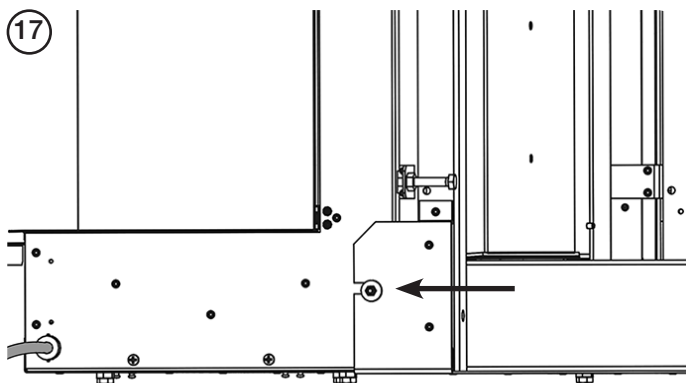

Fit the flue.

## FLUE ASSEMBLY

**TAKE CARE WHEN MARKING OUT FOR THE FLUE AS IT IS DIFFICULT TO MOVE AFTER INSTALLATION. IF A RESTRICTOR IS REQUIRED FIT THIS BETWEEN THE SMALL OUTLET SPIGOT AND THE AIR DUCT. REFER TO TECHNICAL SPECIFICATIONS FOR RESTRICTOR SIZE.**

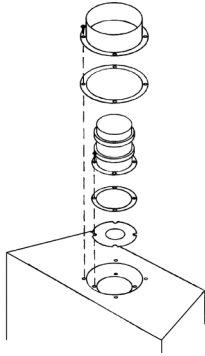

A 208mm diameter hole in the wall is required to install the flue. This can be achieved by using either:

- a) Core drill
- b) Hammer and chisel

Drill small holes around the circumference when using method b). Make good both ends of the hole.

Allow enough room either above or to the side of the appliance to assemble the flue on top.

Assemble a horizontal flue in the following order:

- Vertical section
- 90° elbow
- Horizontal plus terminal

Only the horizontal terminal section can be reduced in size.

To find the length:

Measure from the outside of the wall to the stop on the 90° elbow.

**Add 10mm to the outlet end.**

Measure from the edge of the slots closest to the wall.

Mark around the flue.

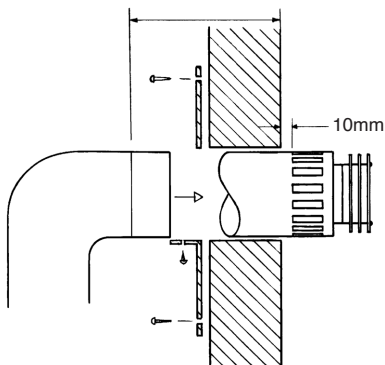

Bend the tab to 90°.

Assemble the plate onto the flue but do not secure to wall until the flue is fully assembled.

The cardboard fitment in the terminal is used to support the flue whilst it is cut to length. **ONCE CUT TO SIZE REMOVE THE CARDBOARD REMNANT.**

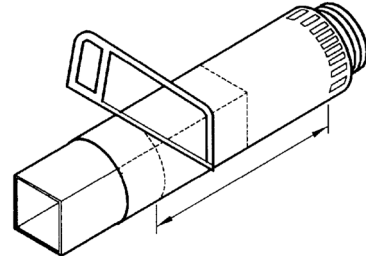

## ENCLOSURE CONSTRUCTION - 3 SIDED INSTALLATION

### Example enclosure

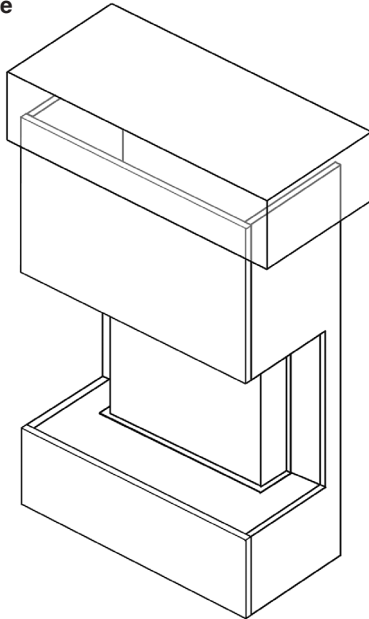

### VENTILATION



**Note:** If the lower section of the enclosure is sealed (to the floor or capped if designed as a floating shelf) it will be necessary to provide a vent with a minimum free area of 150cm<sup>2</sup>.

If the upper section is sealed (to the ceiling or capped if designed as a floating shelf) it will be necessary to provide a vent with a minimum free area of 400cm<sup>2</sup>.

Gazco recommend building the enclosure from the following materials:

Metal Studwork

Non-combustible board:

Masterboard or Promafour - NOT PINK BOARD

Heat Resistant Plaster: Purimacho (any spider cracks that develop after installation will need to be rubbed down and refilled with Purimacho heat resistant filler to stabilise).

Ensure all distances to combustible materials are maintained.

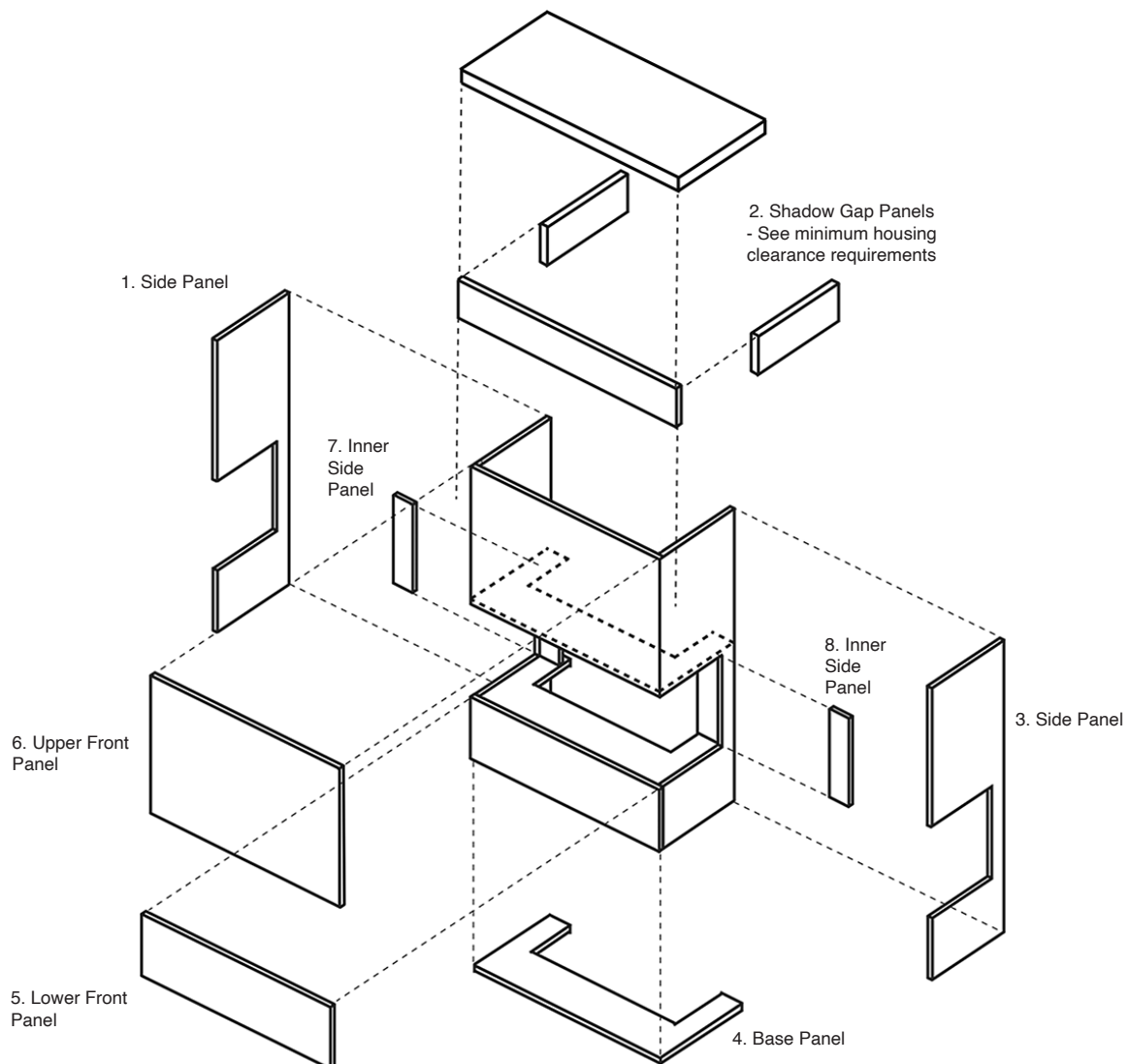

### 3 SIDED INSTALLATION -CUTTING TEMPLATES

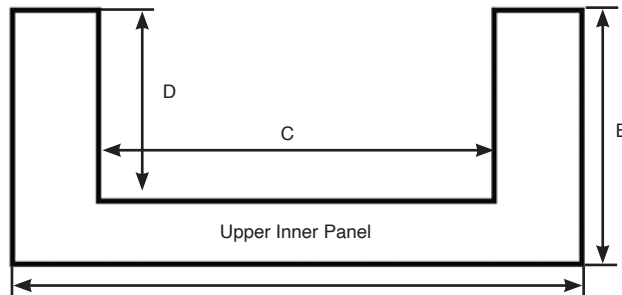
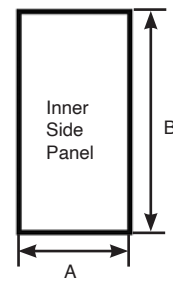
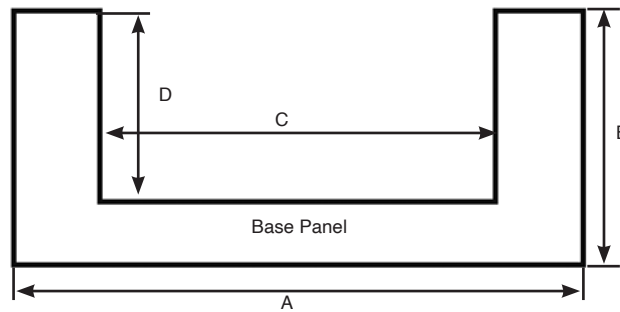
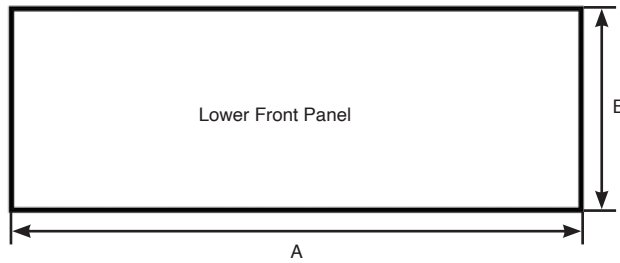
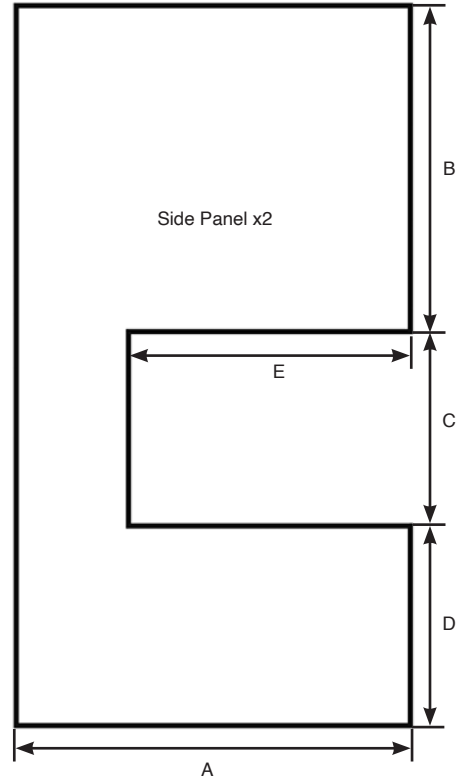
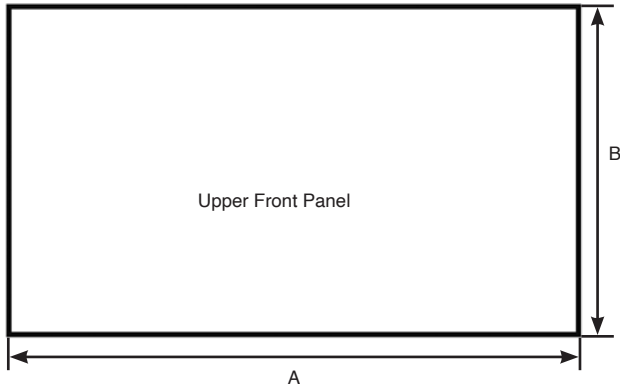

PANEL	A (MIN)	B (MIN)	C	D (MIN)	E (MIN)
Upper Front Panel	1625mm	1000mm	-	-	-
Side Panel x 2	482mm	1000mm	586mm	138mm	371mm
Lower Front Panel	1625mm	138mm	-	-	-
Base Panel	1625mm	482mm	1225mm	397mm	-
Inner Side Panel x 2	215mm	586mm	-	-	-
Upper Inner Panel	1625mm	482mm	1225mm	415mm	-

### 3 SIDED INSTALLATION - SHADOW GAP CUTTING TEMPLATES

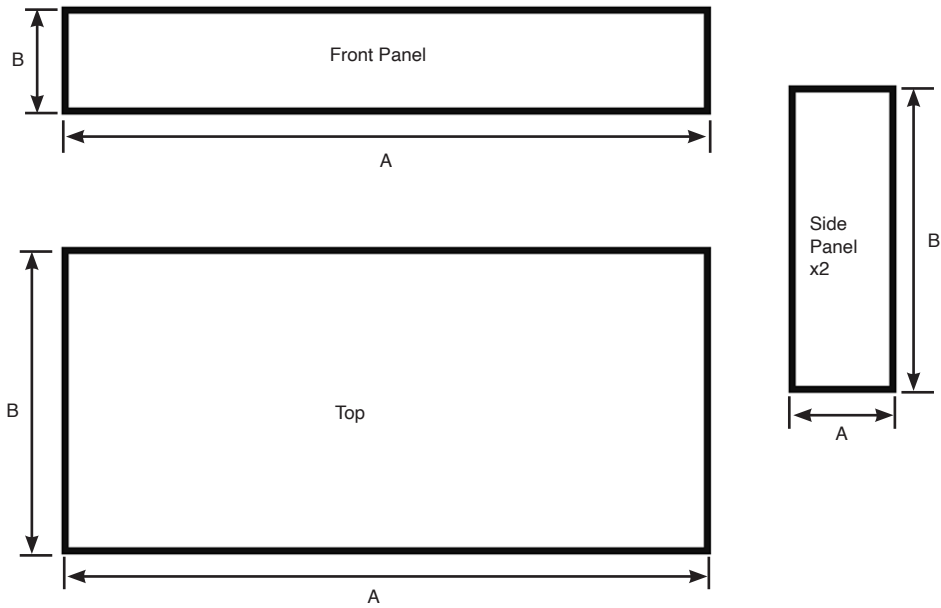

PANEL	A (MIN)		B (MIN)	
	FLOOR MOUNTED	WALL MOUNTED	FLOOR MOUNTED	WALL MOUNTED
Front Panel	1787mm	1587mm	100mm	
Side Panel x2	1000mm		509mm	
Top	1787mm	1587mm	509mm	

### 3 SIDED CONSTRUCTION

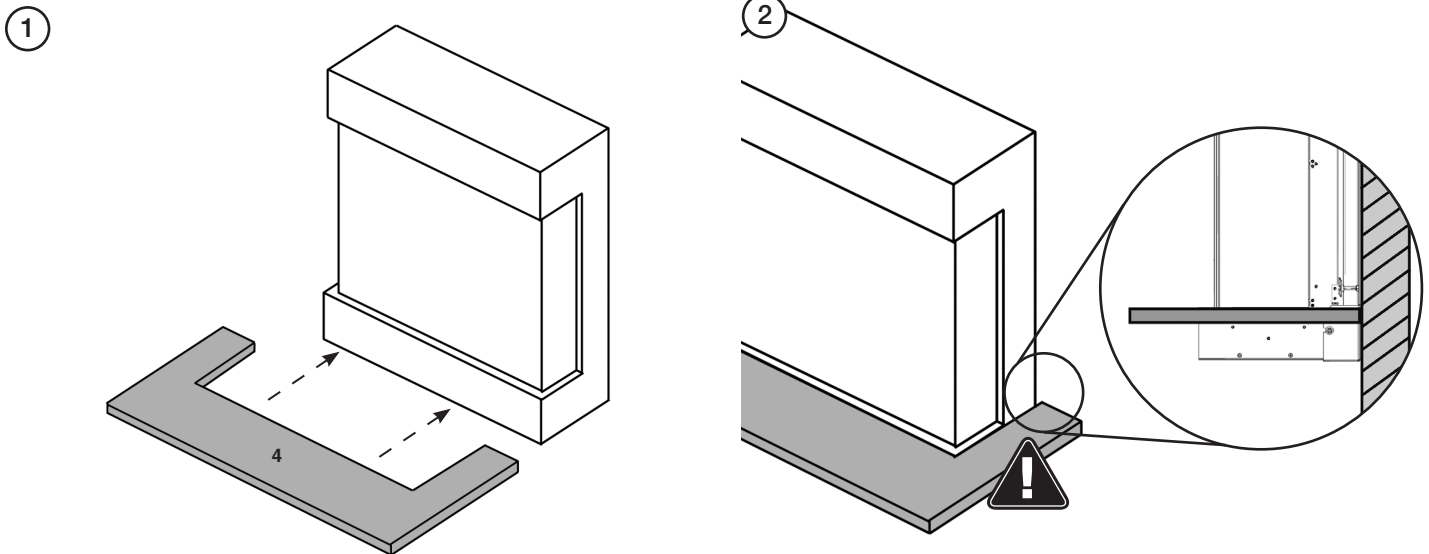

**IMPORTANT: THE BASE PANEL MUST SEAL COMPLETELY TO THE SUPPORTING WALL.**

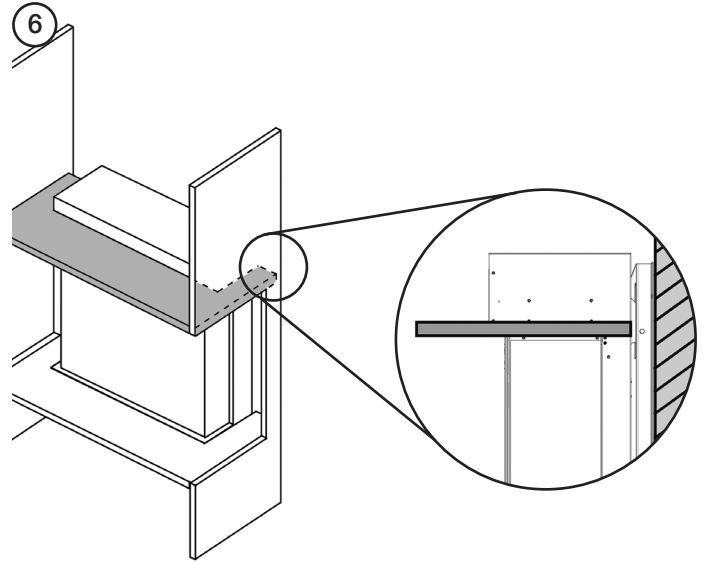
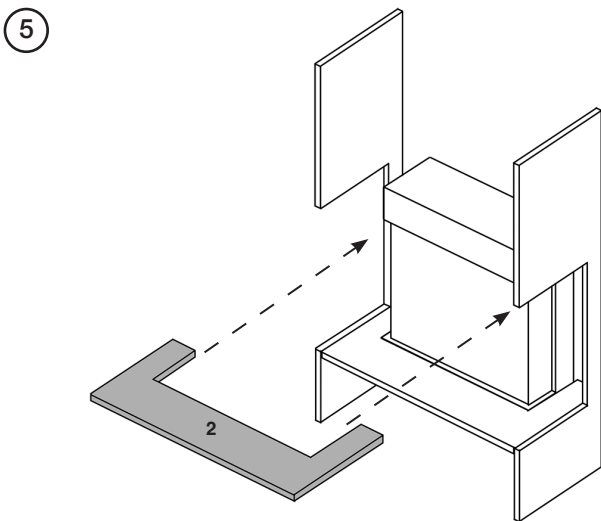
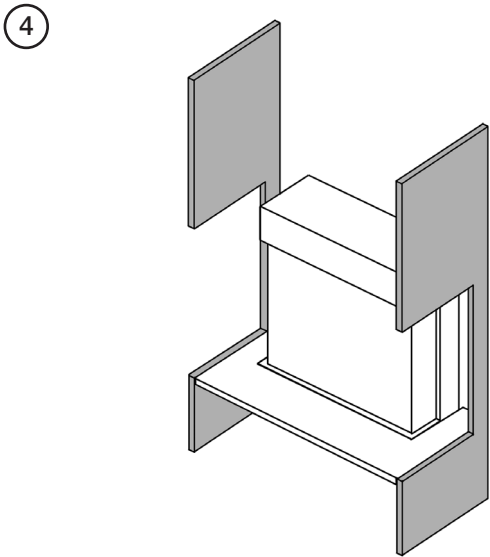
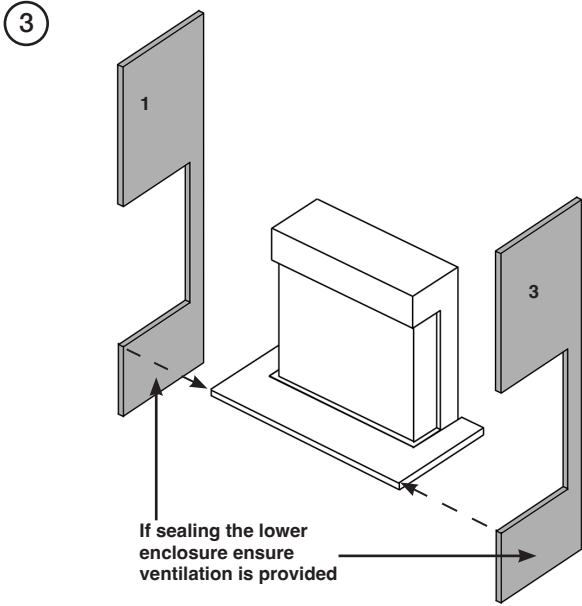

**i** NOTE: IT IS NOT NECESSARY TO SEAL THE UPPER ENCLOSURE BACK TO THE SUPPORTING WALL.

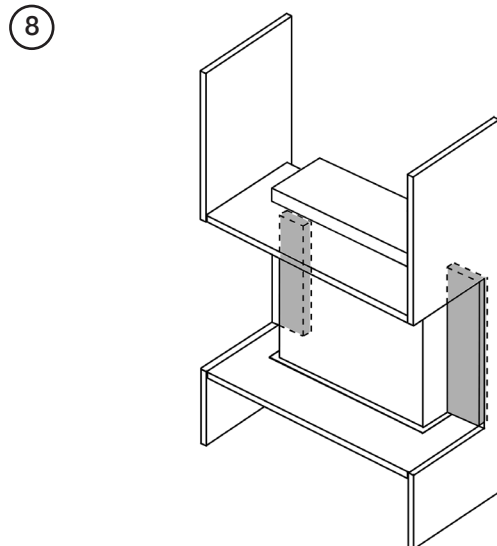
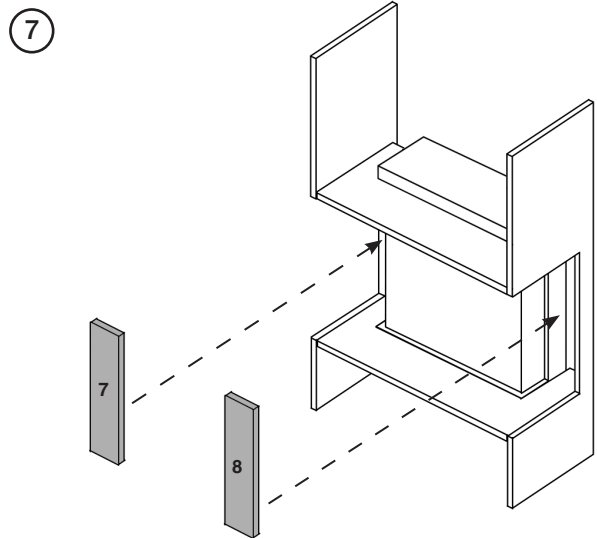

9

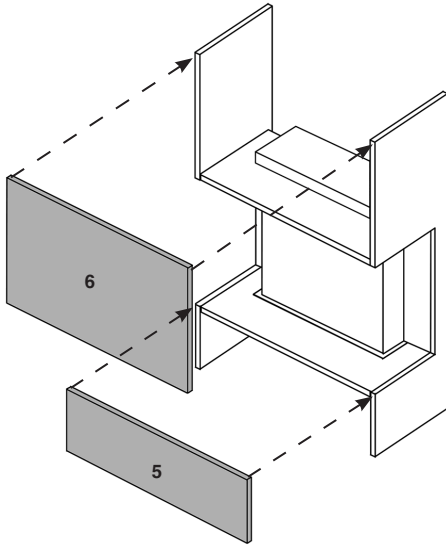

10

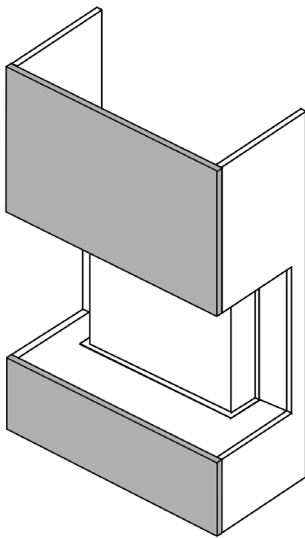

VENTED INSTALLATION - CEILING HEIGHT

11

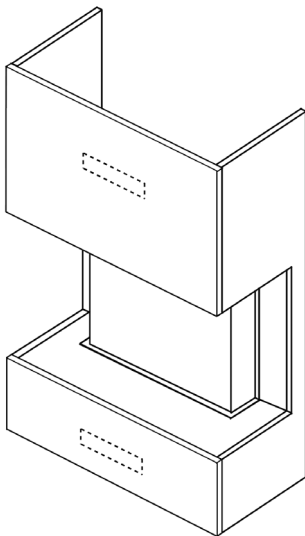

SHADOW GAP INSTALLATION

12

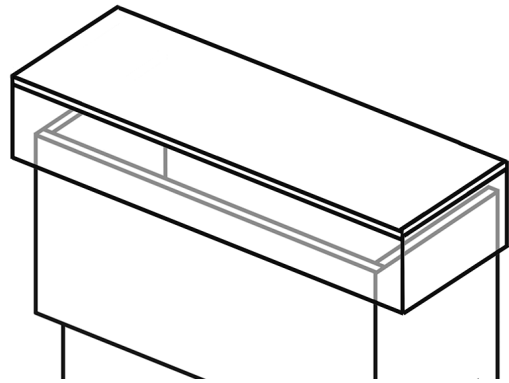

13

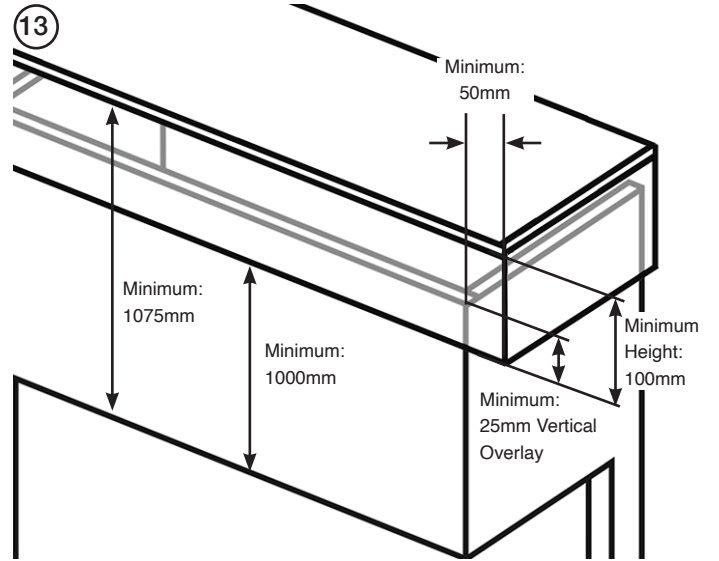

Top View

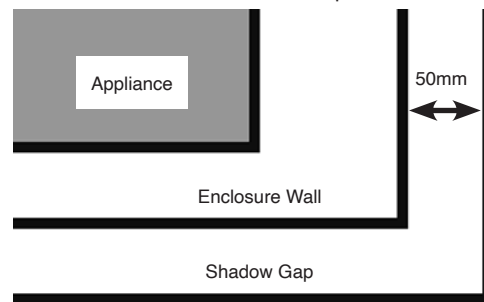

## ENCLOSURE CONSTRUCTION - 2 SIDED INSTALLATION

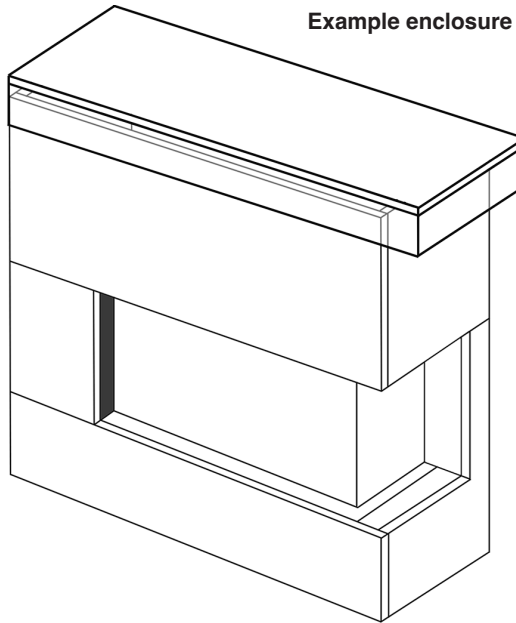

### VENTILATION

Note: If the lower section of the enclosure is sealed (to the floor or capped if designed as a floating shelf) it will be necessary to provide a vent with a minimum free area of 150cm<sup>2</sup>.

If the upper section is sealed (to the ceiling or capped if designed as a floating shelf) it will be necessary to provide a vent with a minimum free area of 400cm<sup>2</sup>.

Gazco recommend building the enclosure from the following materials:

Metal Studwork

Non-combustible board:

Masterboard or Promafour - NOT PINK BOARD

Heat Resistant Plaster: Purimacho (any spider cracks that develop after installation will need to be rubbed down and refilled with Purimacho heat resistant filler to stabilise).

Ensure all distances to combustible materials are maintained.

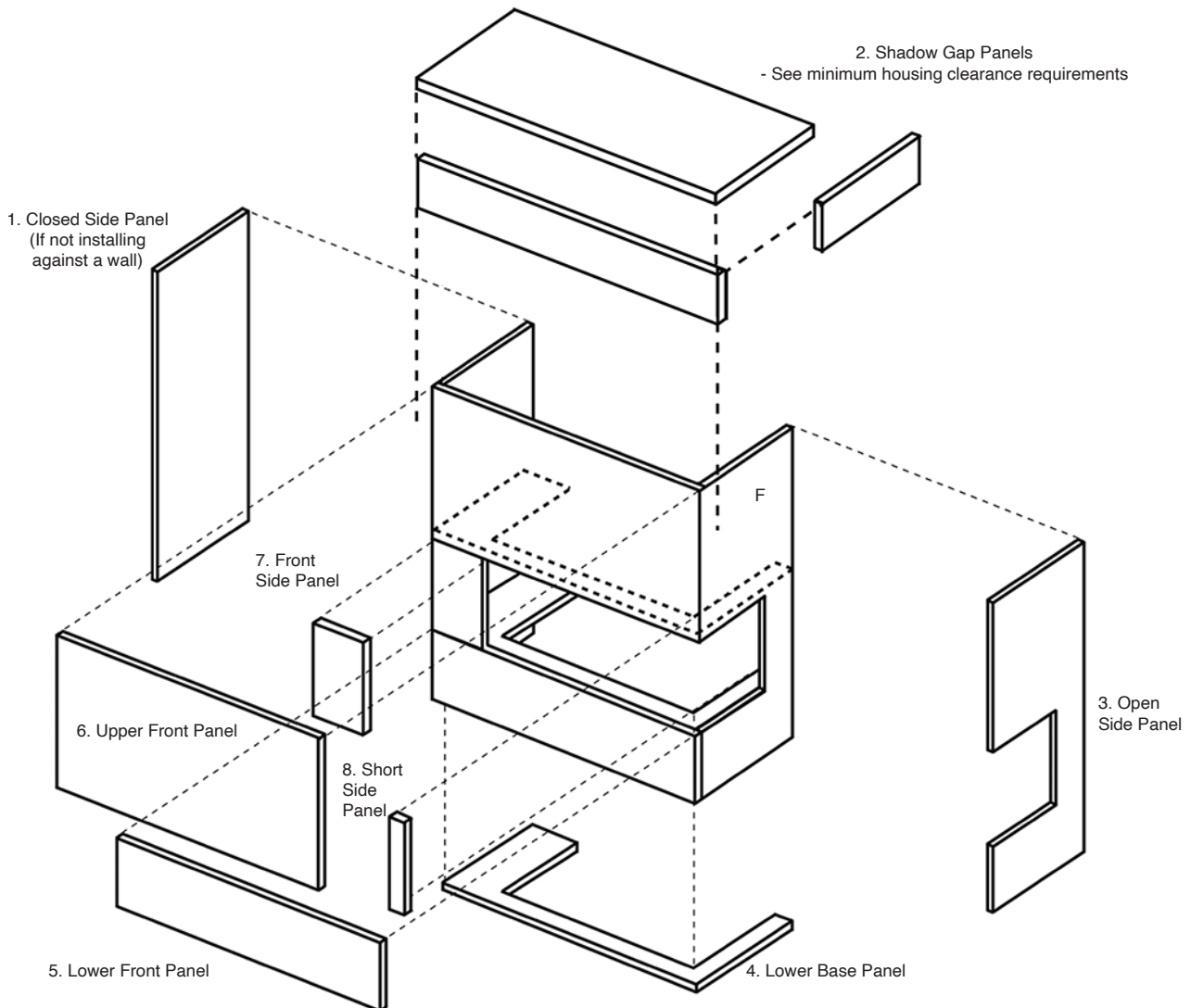

**2 SIDED INSTALLATION  
- CUTTING TEMPLATES**

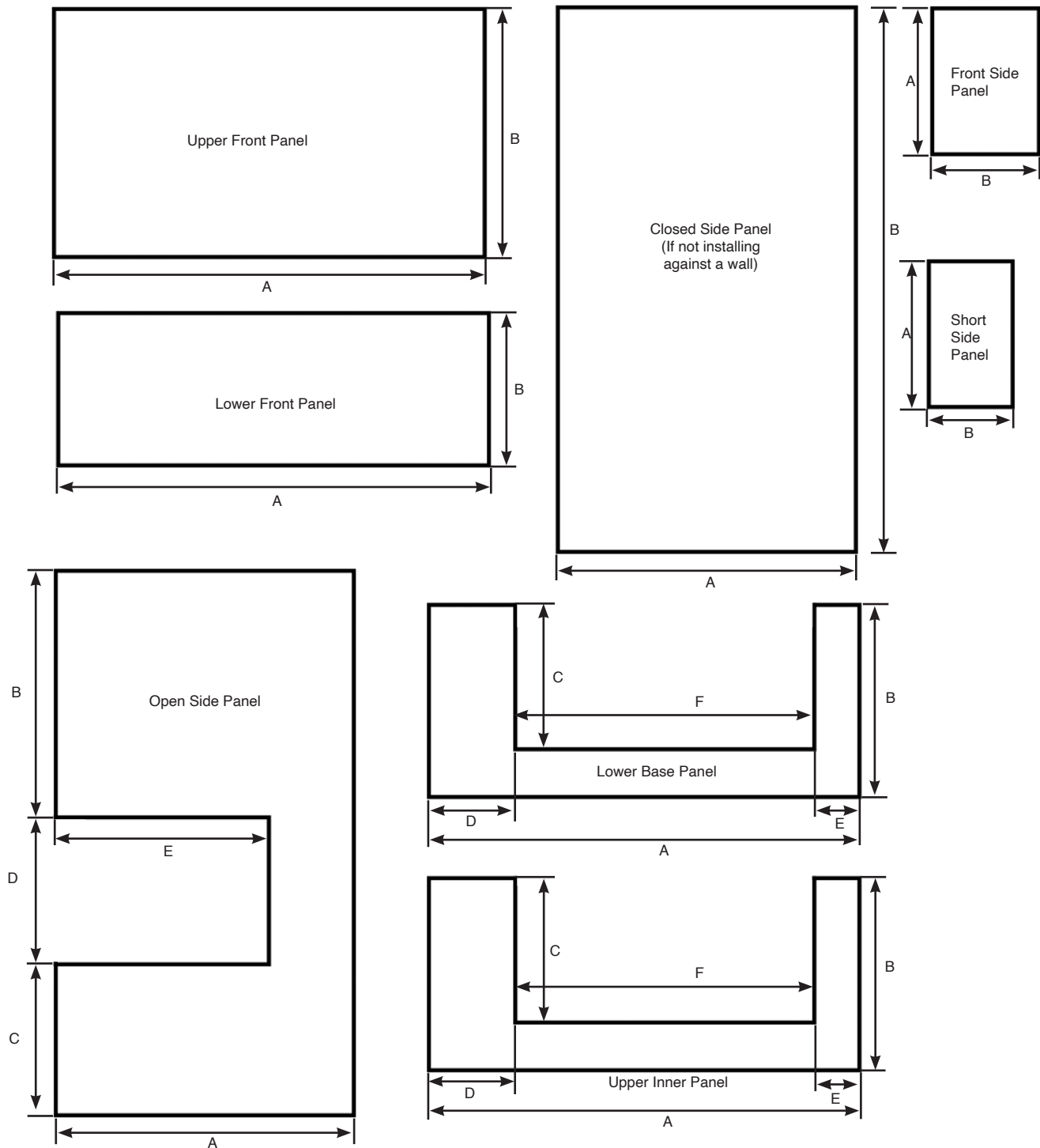

PANEL	A (MIN)	B (MIN)	C (MIN)	D	E	F
Upper Front Panel	1475mm	1000mm	-	-	-	-
Open Side Panel	482mm	1000mm	138mm	586mm	397mm	-
Closed Side Panel (If not installing against a wall)	482mm	1724mm	-	-	-	-
Lower Front Panel	1475mm	138mm	-	-	-	-
Lower Base Panel	1475mm	482mm	397mm	215mm	50mm	1225mm
Front Side Panel	586mm	200mm	-	-	-	-
Upper Inner Panel	1475mm	482mm	415mm	215mm	50mm	1225mm
Short Side Panel	586mm	65mm	-	-	-	-

**2 SIDED INSTALLATION  
- SHADOW GAP CUTTING TEMPLATES**

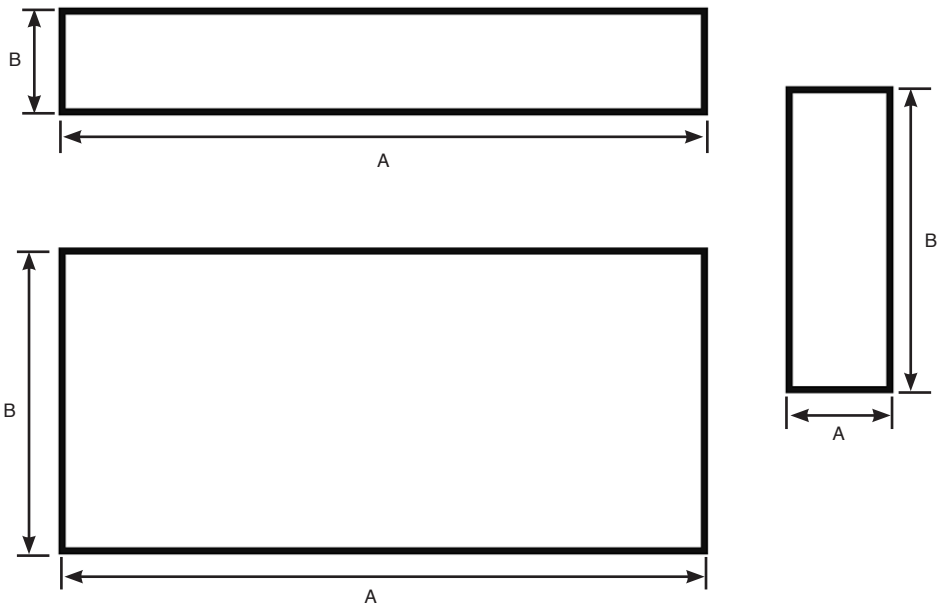

PANEL	A (MIN)		B (MIN)	
	FLOOR MOUNTED	WALL MOUNTED	FLOOR MOUNTED	WALL MOUNTED
Front Panel	1687mm	1487mm	100mm	
Side Panel x2	1000mm		509mm	
Top	1687mm	1487mm	509mm	

**2 SIDED CONSTRUCTION**

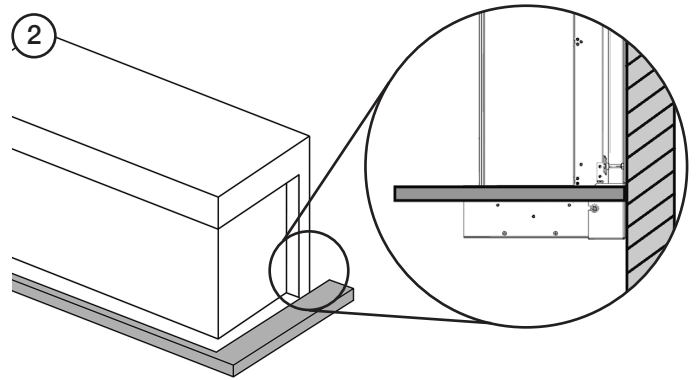
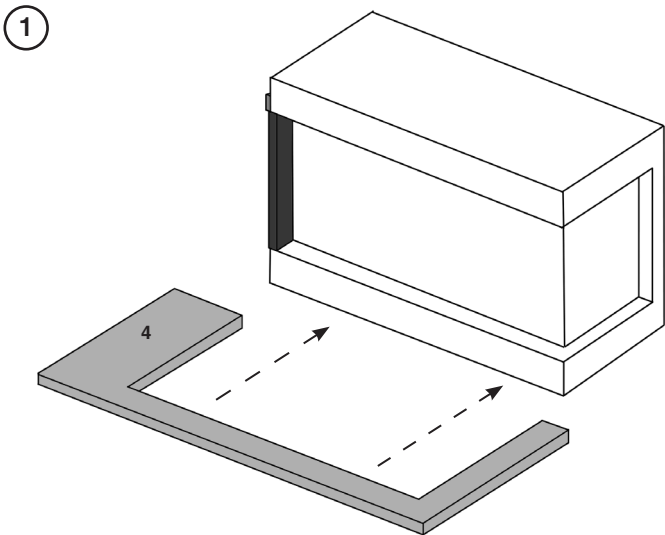

**IMPORTANT: THE BASE PANEL MUST SEAL COMPLETELY TO THE SUPPORTING WALL.**

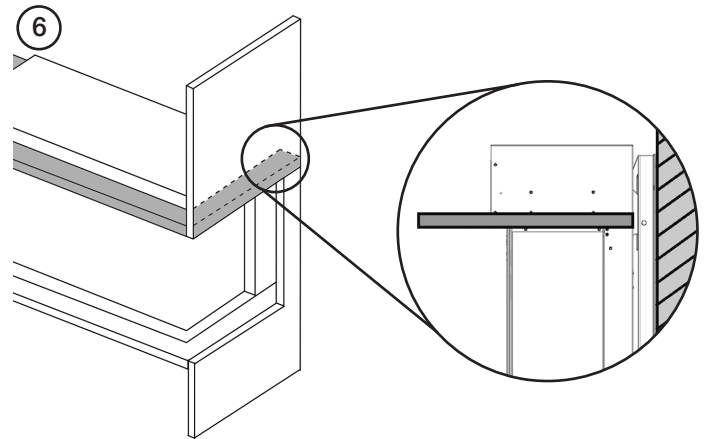
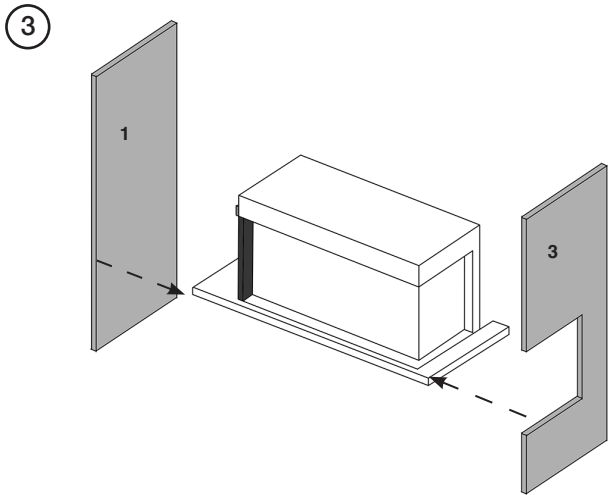

**i** NOTE: IT IS NOT NECESSARY TO SEAL THE UPPER ENCLOSURE BACK TO THE SUPPORTING WALL.

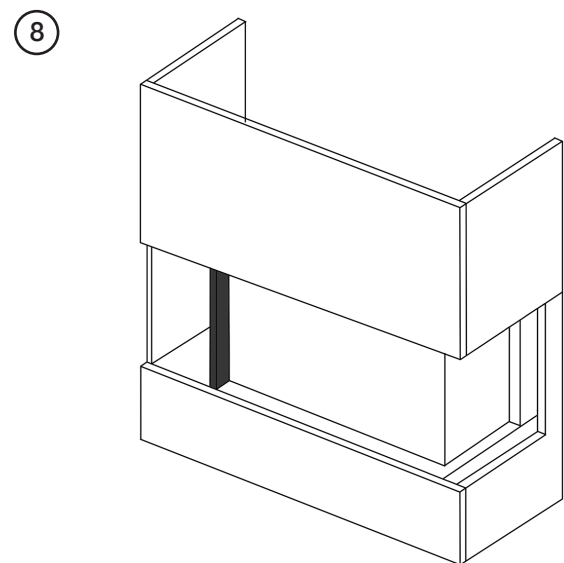
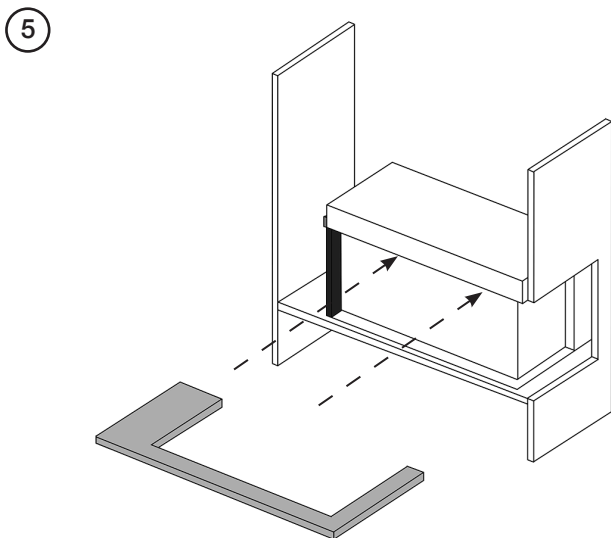
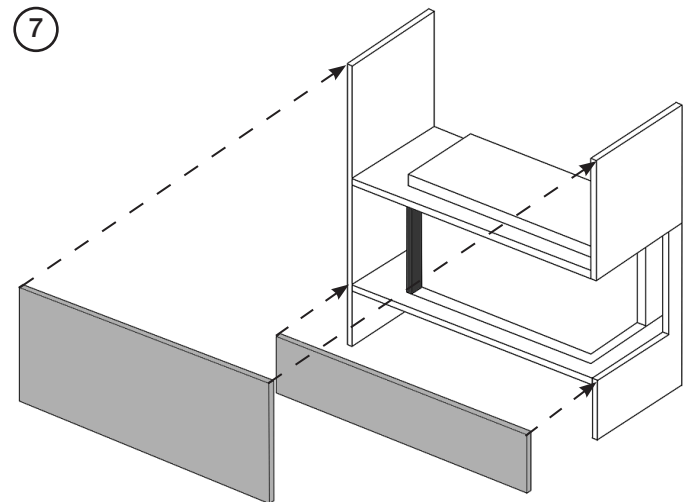
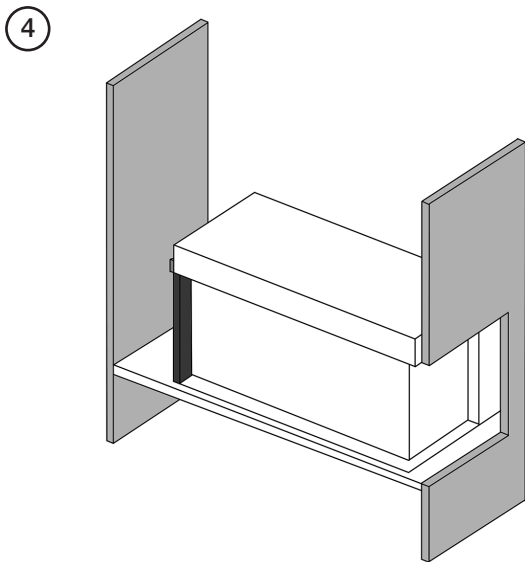

9

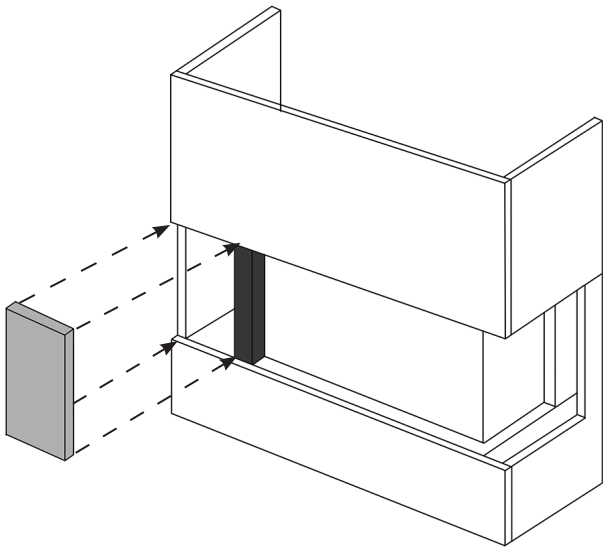

12

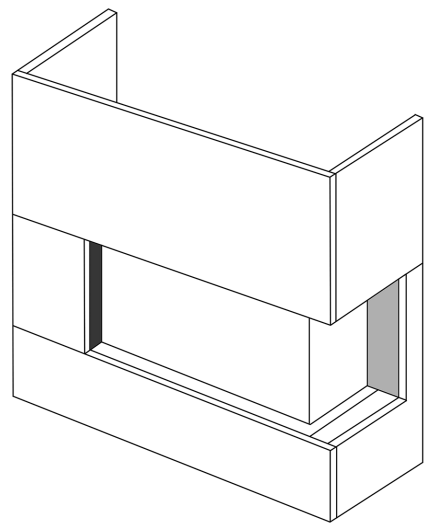

10

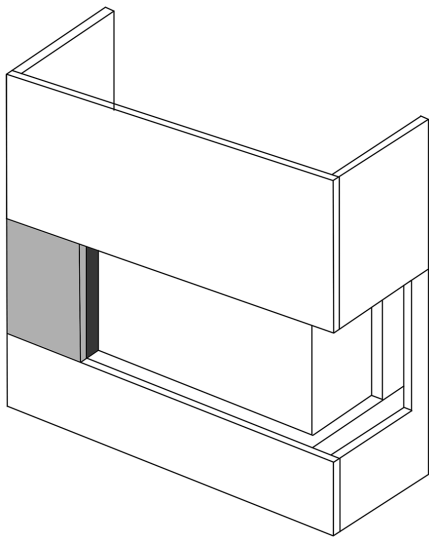

VENTED INSTALLATION - CEILING HEIGHT

13

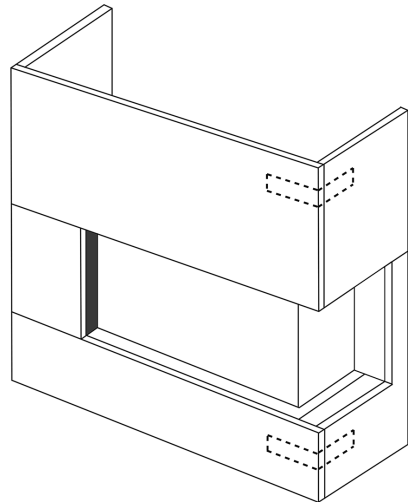

11

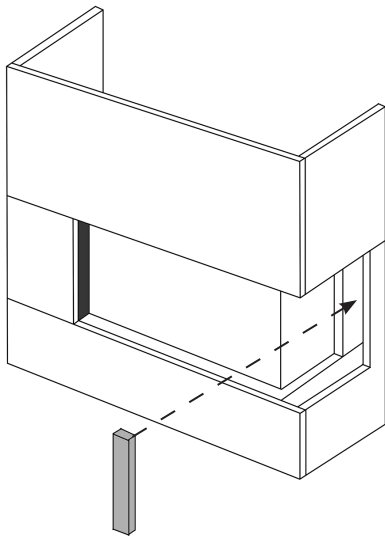

SHADOW GAP INSTALLATION

14

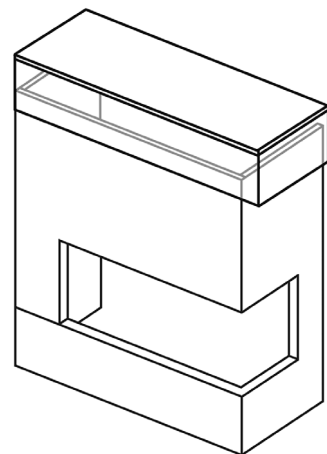

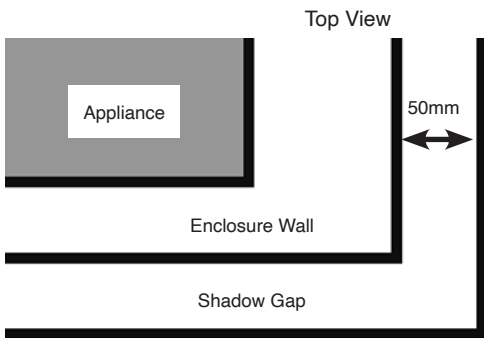
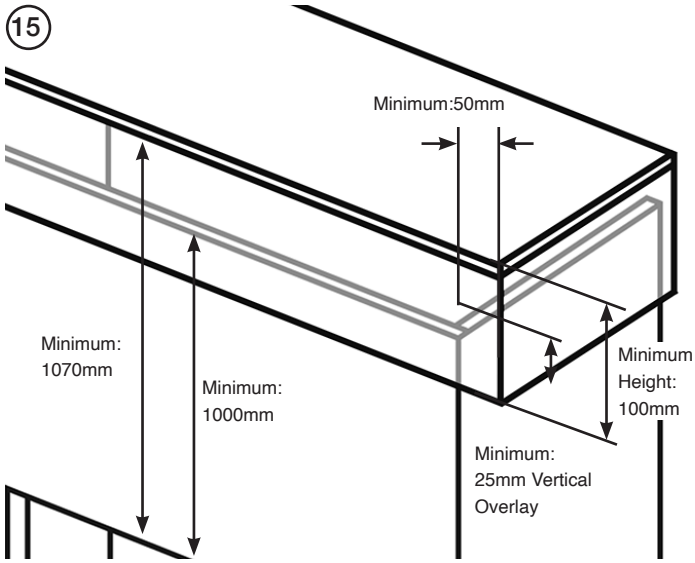

## INSTALLATION

### GAS SOUNDNESS PRESSURE CHECK

This is a working pressure test and must be carried out with all other gas appliances in the property in operation.

Connect a suitable pressure gauge to the test point located on the inlet fitting. Turn the gas supply on.

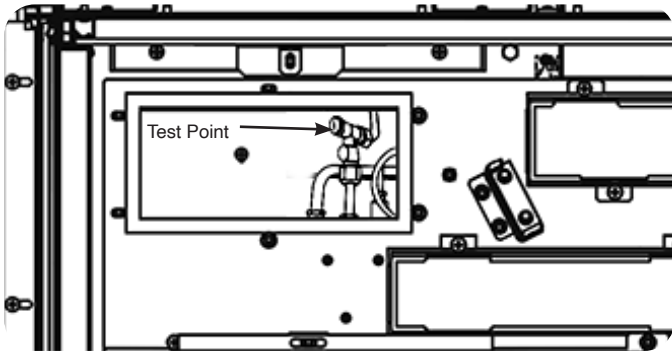

Remove the fixing screws and loosely place the appropriate burners onto the injectors.

Light the appliance and check all gas joints for possible leaks. Turn the appliance to maximum and check that the supply pressure is as stated on the databadge. Turn the appliance off. Replace the test point screw and check the test point for leaks.

Remove the burners. Take care as the burners will be hot.

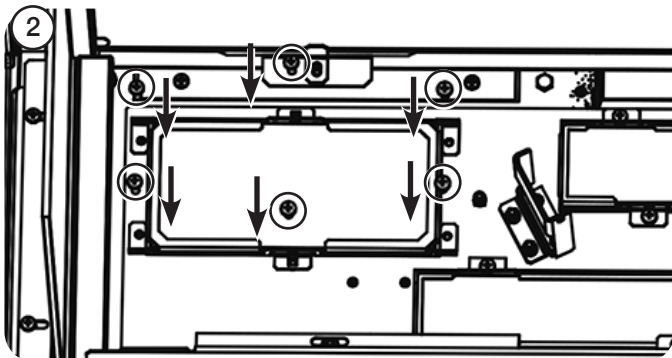
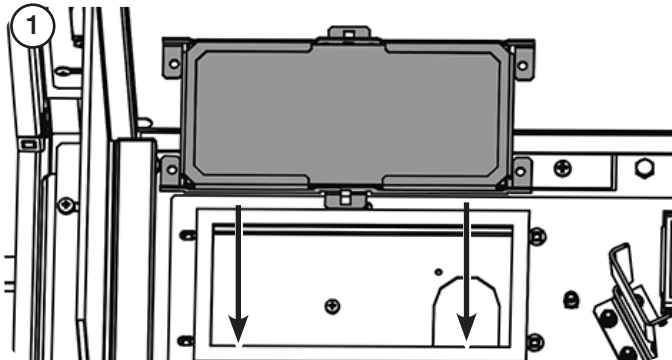

### ASSEMBLING THE FUEL BED

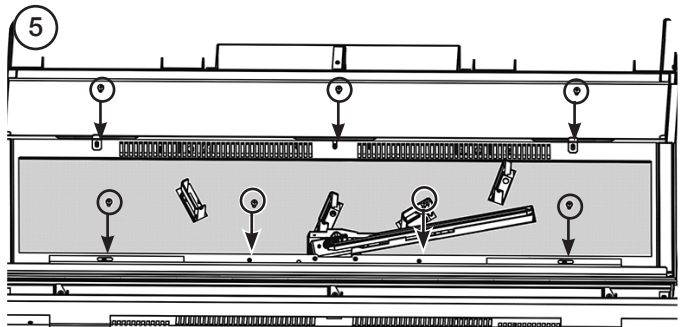
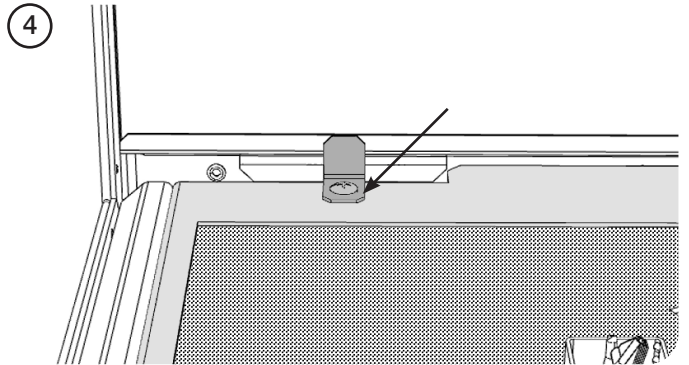
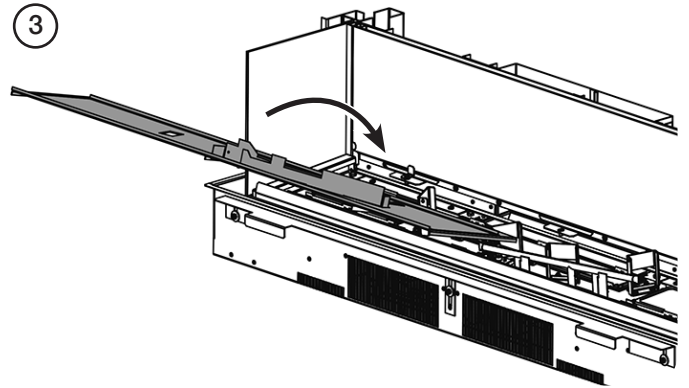

**NOTE:** Ensure the 2 brackets at the rear are pushed as far back as possible before tightening.

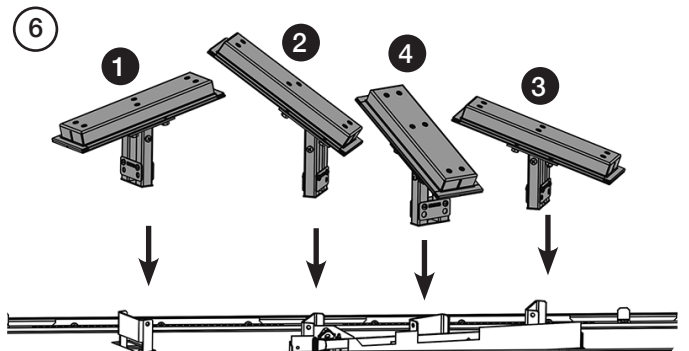

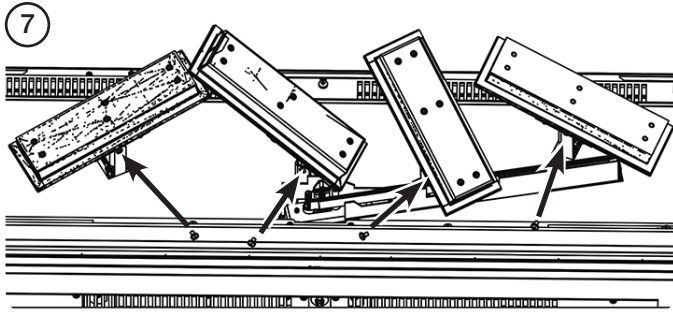

**NOTE:** Some burners are pre-fitted with Aeration plates. These are non-serviceable and **MUST NOT** be altered.

### ARRANGEMENT OF FUEL BED COMPONENTS

**TAKE CARE NOT TO SPILL THE FUEL EFFECT INTO THE PILOT AREA. ONLY GENUINE GAZCO PARTS CAN BE USED IN THIS APPLIANCE.**

Use the entire bag of supplied Amber Effect.

The Shale Effect is supplied as large pieces which will need to be broken into 2-3 smaller shards before placing onto the fuel bed. It is not necessary to use all the supplied Shale Effect.

### LOG LAYOUT

**LOGS MUST BE POSITIONED ACCORDING TO THE FOLLOWING INSTRUCTIONS TO GIVE THE CORRECT FLAME EFFECT. THE 3 BURNER LOGS MUST LOCATE CORRECTLY ONTO THE LOG BURNERS. ENSURE THE AMBER EFFECT DOES NOT CAUSE THE LOGS TO LIFT OFF THE BURNER.**

Ensure the Burner Tray and Log Burners are clean and free from any debris.  
The main components are clearly individually labelled.

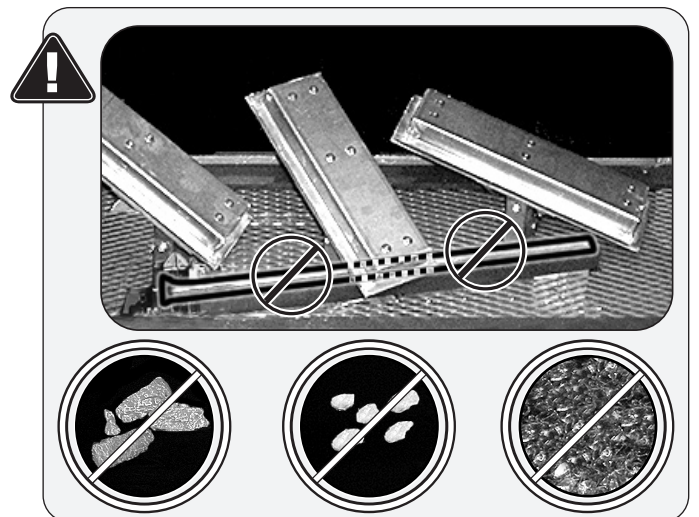
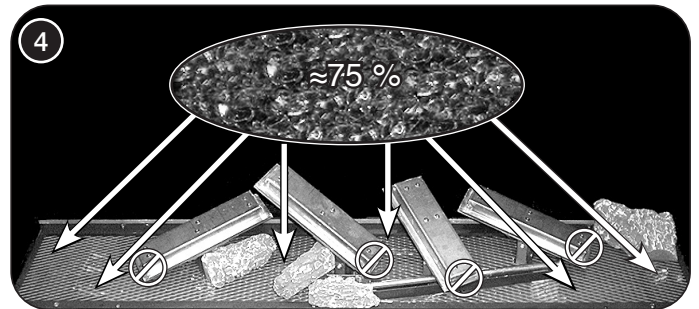
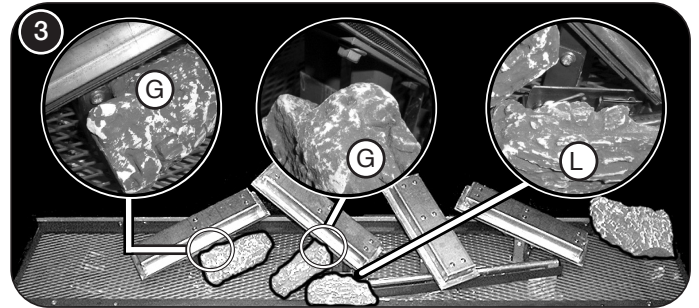
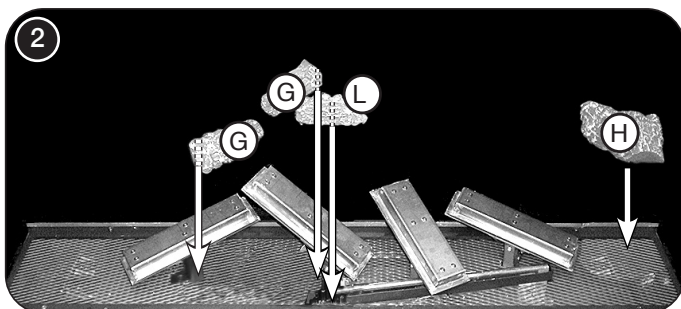
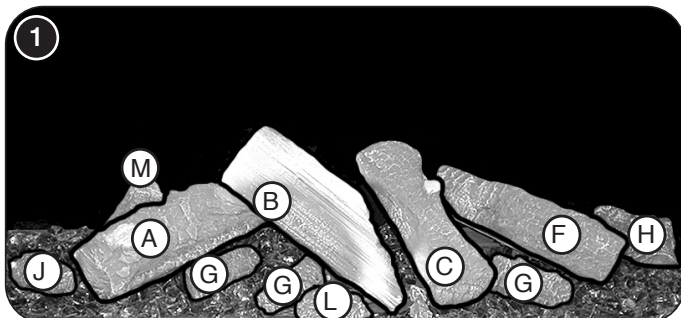

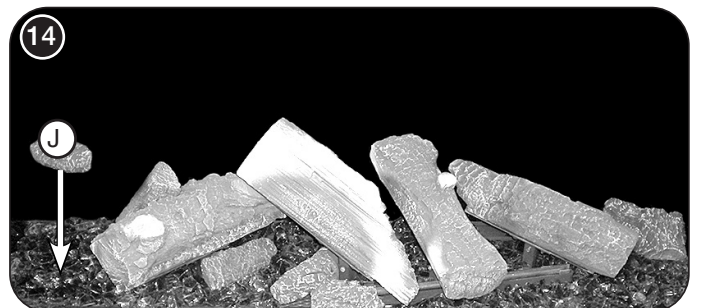
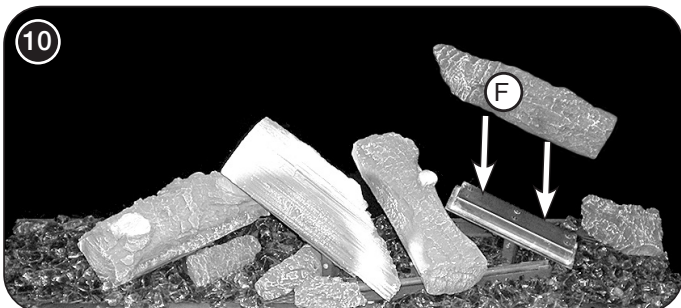
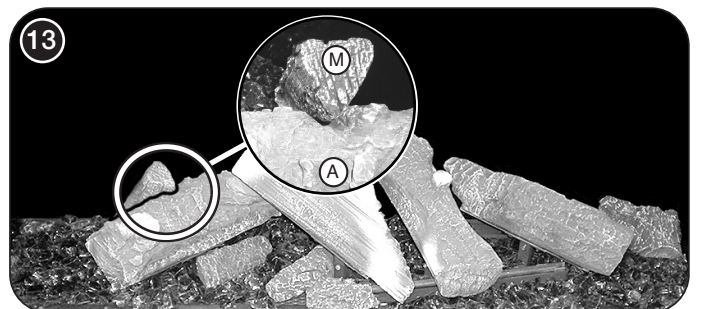
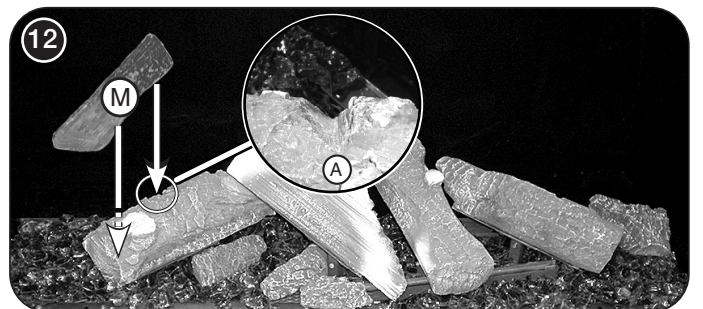
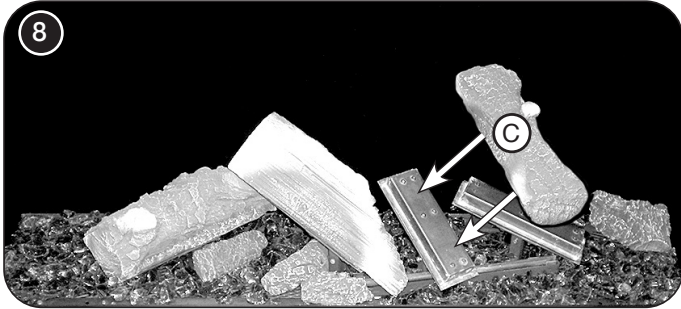
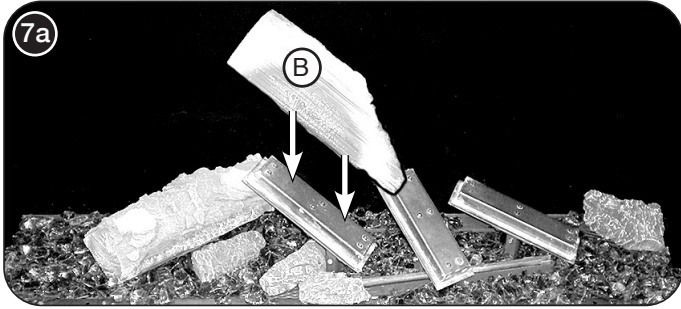

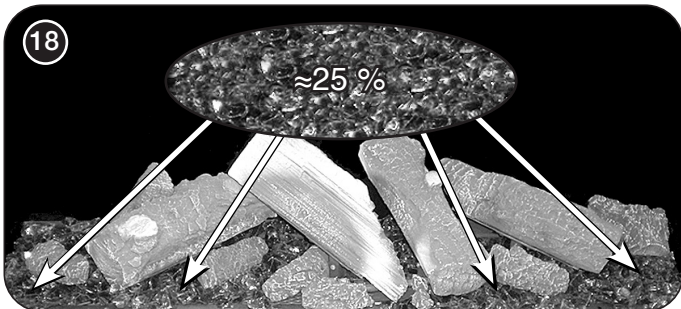
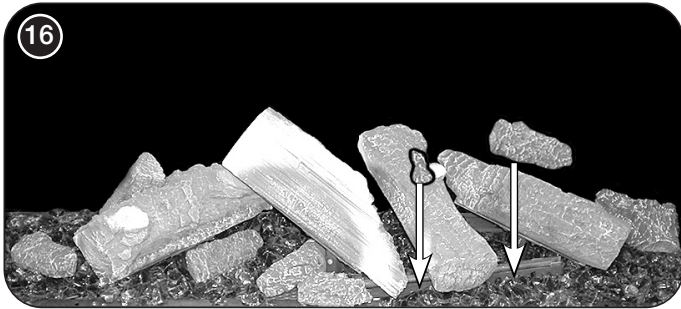
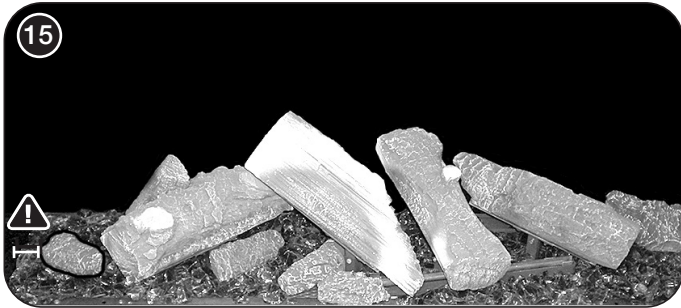

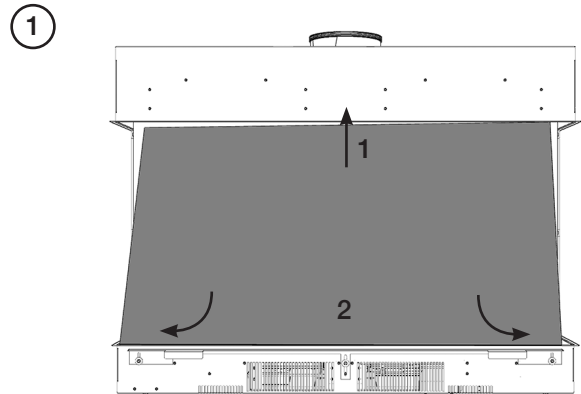

 **NOTE: ENSURE THAT THE LOGS ARE POSITIONED AS ABOVE. ONLY USE THE CORRECT AMOUNT OF LOGS AS SPECIFIED IN THE DIAGRAMS.**

## COMPLETION OF ASSEMBLY



 **THE FRONT GLASS SHOULD PRESS FIRMLY AGAINST THE SIDE GLASS.**

Check the alignment of all the glass panels to ensure the Front Glass and Side Glass all sit flush to one another.

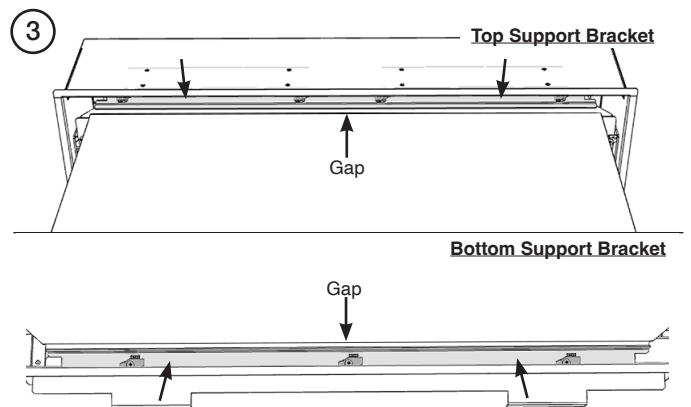
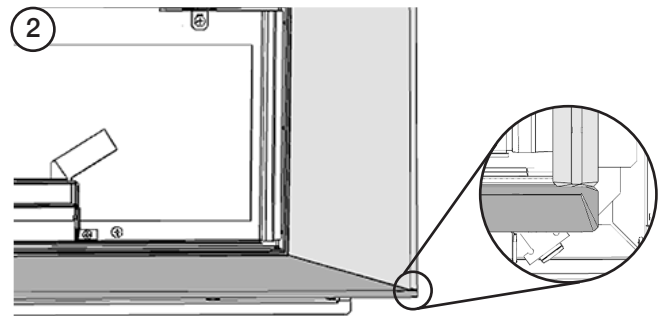

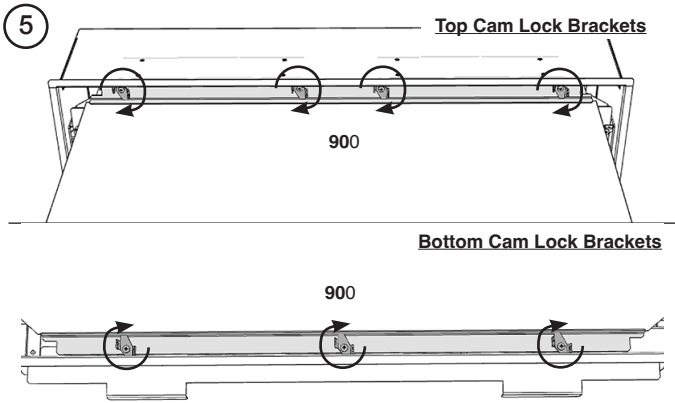
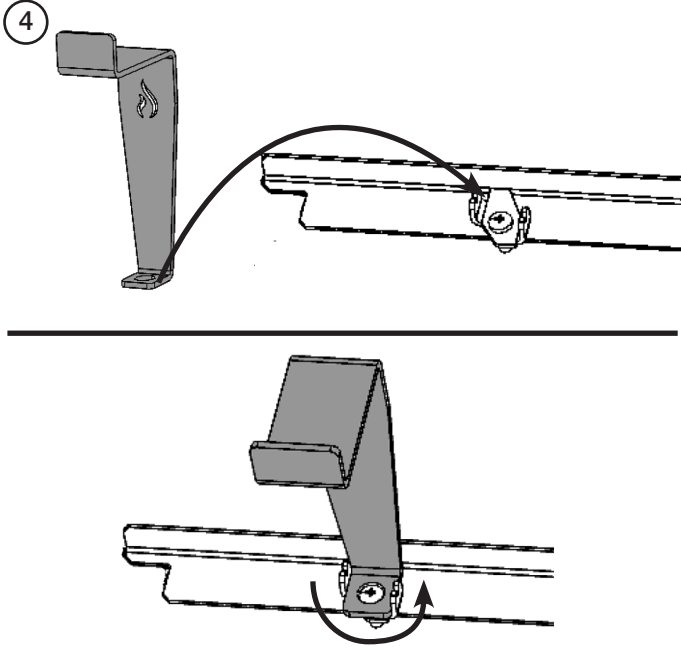

**!** UNDER NO CIRCUMSTANCES SHOULD THE APPLIANCE BE USED IF ANY OF THE GLASS PANELS ARE LOOSE, DAMAGED, OR MISSING.

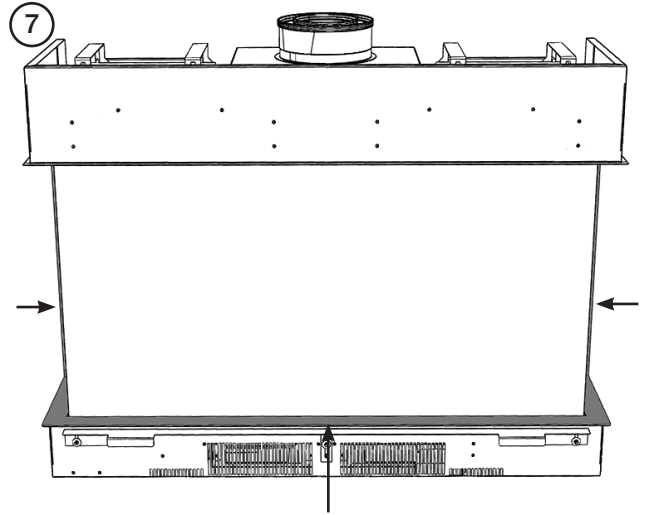
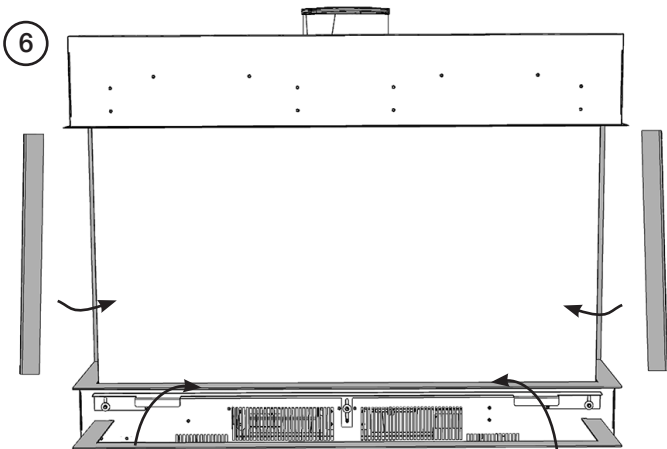

**ENSURE THAT ALL GLASS PANELS ARE FLUSH AND THAT THERE ARE NO GAPS BETWEEN PANELS.**

## LIGHTING THE APPLIANCE

The appliance is operated by thermostatic and programmable remote control.

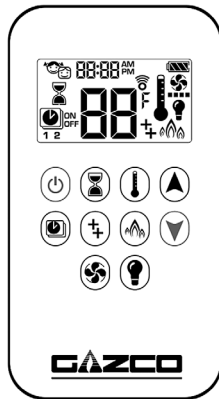

Via the remote it is possible to control the following features:

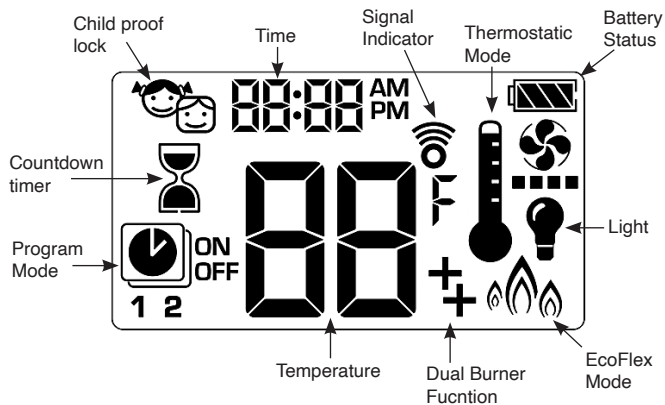



## TURNING THE APPLIANCE ON

The handset controls the appliance from pilot ignition through to shut down.

To turn the fire on press the  button until two short signals and a series of blinking lines on the handset confirm the start of the ignition sequence and there will be a clicking sound as the valve opens on the appliance.

**The pilot will ignite and the remote is now in Manual Mode.**  
**The first time the appliance is turned on it will light in the High position.**

 **IMPORTANT: YELLOW FLAMES TYPICALLY APPEAR WHEN THE APPLIANCE HAS REACHED NORMAL OPERATING TEMPERATURE. THIS CAN TAKE UP TO 30 MINUTES.**

 **WARNING: IF THE APPLIANCE FAILS TO LIGHT OR BECOMES EXTINGUISHED IN USE, WAIT 3 MINUTES BEFORE ATTEMPTING TO RELIGHT.**

## TURNING THE APPLIANCE OFF (STANDBY)

Press and hold the  button to turn the appliance off.

NOTE: There is a 5 second delay before the next ignition is possible.

## TROUBLESHOOTING



**IMPORTANT:** In the unlikely event that the handset fails to communicate correctly with the appliance it may be necessary to turn off the gas supply at the isolation valve until any problems can be resolved.

The gas meter and isolation valve can be located outside in a meter box, under the stairs, beneath the kitchen sink or in the garage. Whilst this list is not exhaustive, it is important to be able to identify the location of the valve in case of any gas emergency.

To turn off the gas supply, simply turn the handle so the lever is at 90 degrees to the upright gas pipe.

If you smell gas, open doors and windows and never operate any electrical switches. Immediately call the Gas Emergency Services on 0800 111 999.

## MYFIRE WI-FI INSTALLATION

**BEFORE UNDERTAKING ANY WORK SWITCH OFF THE APPLIANCE AND ISOLATE THE POWER SUPPLY ENSURING THERE IS NO POWER TO THE APPLIANCE.**

Remove the Front Glass.

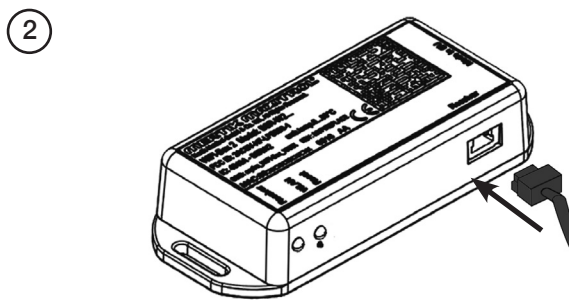
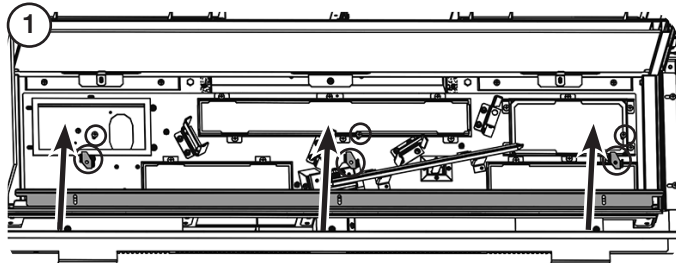

Position the Wi-Fi module in the Wi-Fi module bracket.

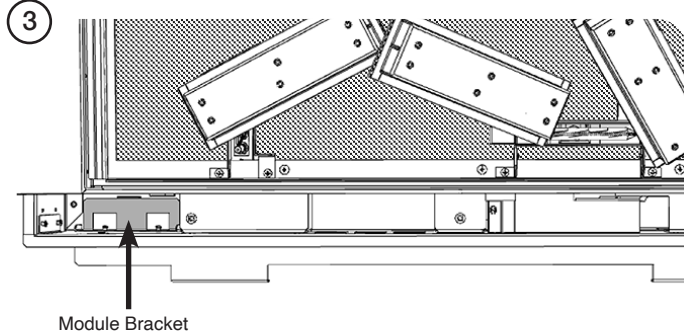

The receiver is located beneath the Main Control Assembly, close to the pilot area.

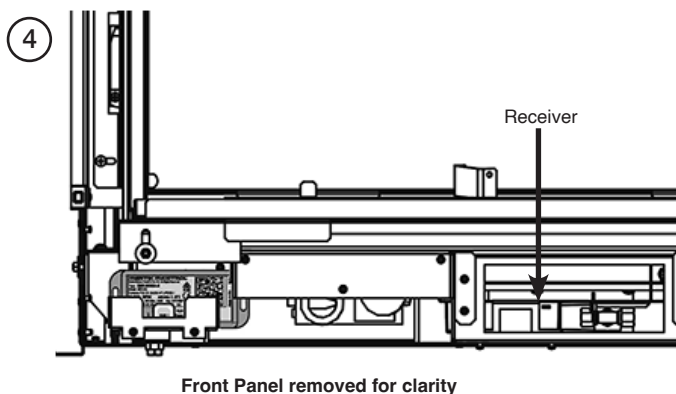

Using long nose pliers connect the other end of the module lead to the receiver.

**Note: Do not force the connector into position, ensure the connector is at the correct orientation before inserting.**

Ensure the module lead runs **underneath** the front panel spacer.

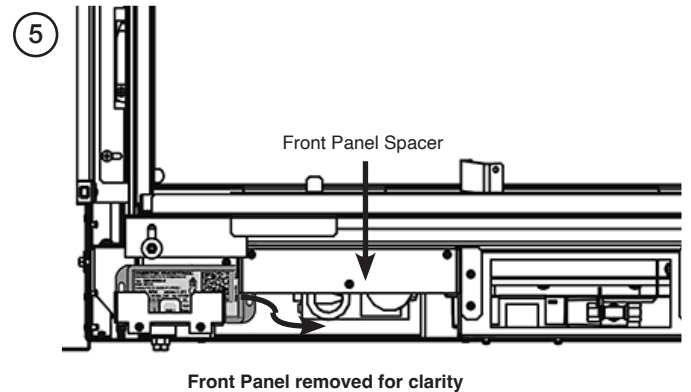

This should complete the wiring circuit as shown.

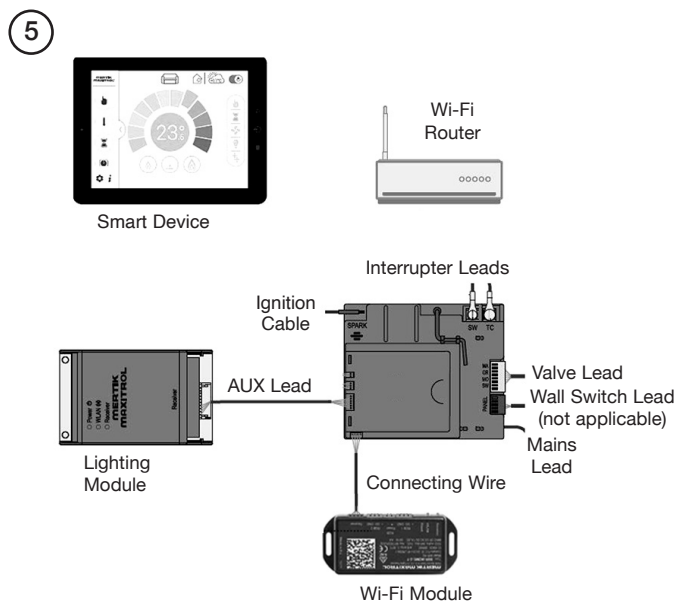

**NOTE: Ensure none of the wires are snagged or caught on any internal components.**

Follow the steps listed in the MyFire App Setup manual PR2467 to connect a smart device to the fire.

Replace the Front Glass, Cam Lock Brackets, Glass Support Bracket, and trims.

ENSURE THAT THE GLASS BRACKETS ARE SECURE AND IN THE ORIGINAL ORIENTATION.

The installation is now complete.



Once the Wi-Fi module has been installed and connected to a power source there is a 24 hour window to complete the setup process on the MyFire app.

If setup is not completed in this window the Wi-Fi module will have to be manually reset to complete setup, see Page 45 & PR2467 MyFire App Setup.

Once fitted, remove the trims to access the Wi-Fi module.

## MYFIRE WI-FI SET UP & TROUBLESHOOTING

The MyFire Wi-Fi box must be wired according to the MyFire set up diagram and connected to the receiver, which is in turn connected to the mains power.

Ensure the device is running the most up to date operating system as older models may not be compatible with the MyFire App.

After 30 seconds the MyFire Box goes into Access Point Mode (Green LED flashes). See MyFire App instructions supplied and configure the router.

The following things can affect the Wi-Fi signal on the appliance:

1. Multiple users on the same Wi-Fi channel may interfere with the data transfer. Press the reset button on the MyFire Wi-Fi box for 1 second to change the current channel.
2. If the MyFire Wi-Fi box is not connected to the receiver or is not used it will leave Access Point Mode after 24 hours.
3. If there are multiple fireplaces in the household using MyFire Wi-Fi boxes there must be a minimum of 600mm between them to avoid interference.
4. If there are any changes to the home network then the MyFire Wi-Fi set up must be repeated.

Quick Reference Table.

LED INDICATOR FOR MYFIRE WI-FI BOX			
LABEL	LED		STATUS
Power	Blue	On	Power On
		Off	Power Off
WLAN	Green	On	Connected to home network (Wi-Fi Router)
		Off	Not connected to home network (Wi-Fi Router)
		Flashing	MyFire Wi-Fi Box in Access Point Mode
Receiver	Blue	On	Receiver connected
		Off	No receiver connected or connection lost
All LEDs		Flashing	Internal Configuration

It may be necessary to reset the MyFire Wi-Fi box using a paperclip or similar.

The table below shows the length of time required for each reset and the confirmation signals.

PRESS RESET BUTTON	LED STATUS BLUE POWER LED	FUNCTION
1 Sec	Continuously flashes every ½ second	Activates Access Point Mode for 10mins (connect MyFire Wi-Fi module to home network). Simultaneously the Wi-Fi channel changes.
5 Secs	Two rapid flashes every 1 second	System Reset.
10 Secs	Flashes every 100 milliseconds (Continuous)	Restore factory firmware (MyFire Wi-Fi module will set to default after reboot); takes up to 2 minutes.
20 Secs	Flashes every 50 milliseconds (Continuous)	Restores factory firmware and erases all data not locked. (MyFire Wi-Fi module will set to default after reboot); takes up to 2 minutes.

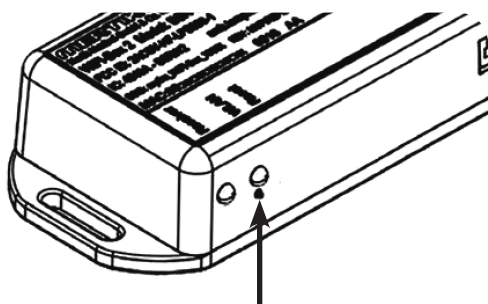

## COMMISSIONING

Complete the Commissioning Checklist at the front of this manual covering:

- Thermocouple soundness checks.  
This is to include ensuring the thermocouple is secure on the pilot bracket assembly, lead connection and integrity.
- Flue checks
- Gas checks
- Log layout - flame picture

For working pressure test, refer to Technical Specifications.

Ensure all safety checks listed in the Commissioning Section are completed, paying particular attention to the glass panel checks and securing of the glass frame.

Upon completion of the commissioning and testing of the installation and correct operation of the appliance, the installer must instruct the user how to operate the appliance.

Guide the user through the User Instructions paying particular attention to:

- a) Regular servicing.
- b) Ventilation - point out the ventilation positions where applicable.
- c) Hot surfaces.
- d) How the appliance works with the remote control handset and the modes of operation.
- e) How to change settings in the auto mode and program modes of operation.
- f) What to do if the appliance fails to operate.

**ENSURE THE APPLIANCE IS REGISTERED WITH GAS SAFE.**

## REPROGRAMMING HANDSET/ CONTROL BOX

To access the control box:

Remove the decorative trim, see Servicing Instructions.

Access is now possible through the aperture below the centre-left hand side of the appliance using an angled pointed tool.

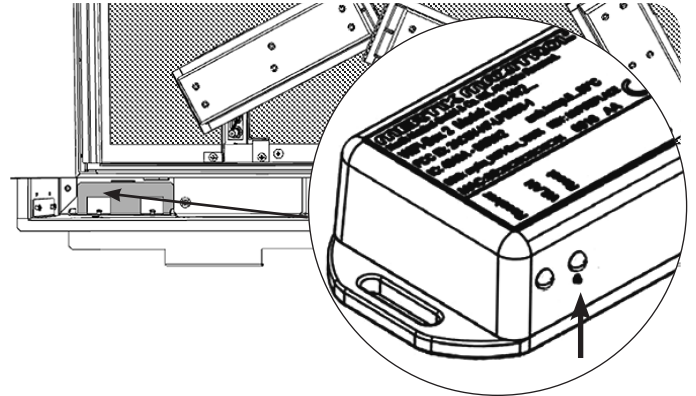

NOTE: Alternatively, the main control assembly can be removed to access the control box, see Servicing Instructions.

Press and hold the reset button on the control box until you hear two signals. After the second longer signal:

Release the reset button and within 20 seconds:

Press the DOWN button on the handset until you hear two additional short signals confirming the new code is set. If there is a single long signal the code learning sequence has failed or the wiring is incorrect.

**Note: When pressing the DOWN button on the handset if two beeps are not heard:**

Release the DOWN button and CONN will be displayed on the handset screen. An 8 second count will start on the handset screen followed by two short beeps confirming the new code is set. If there is a single long signal the code learning sequence has failed or the wiring is incorrect.

Replace the lower glass bracket by setting the cam locks in position with the door tool and tightening the screws.

**Ensure the Front Glass is aligned with the Side Glass.**

## SERVICING INSTRUCTIONS

### SERVICING REQUIREMENTS

**IMPORTANT** – The glass panels on this appliance should be checked for any signs of damage on the front face of the glass panel (scratches, scores, cracks or other surface defects). If damage is observed, the glass panel must be replaced and the appliance must not be used until a replacement is installed. Under no circumstances should the appliance be used if any damage is observed. Please isolate the appliance until a replacement glass panel has been obtained and installed. Replacement glass panels can be purchased from Gazco via the retailer from which the appliance was purchased or any other Gazco distributor.

This appliance must be serviced at least once a year by a competent person.

All tests must be carried out in accordance with the current GasSafe recommendations.

#### BEFORE TESTING:

- Conduct a gas soundness test for the property ensuring there are no leaks before servicing.
- Check the operation of the appliance before testing.

#### SPECIAL CHECKS:

- Clean the burners using a vacuum cleaner with a soft brush attachment. Ensure all debris is removed from the burner ports.
- Clean away lint or fluff from the pilot.
- Clean away lint or fluff from under the burner.
- Check the spark gap on the pilot is correct.
- Check that the Pilot ignites correctly and Main Burner cross lights smoothly.
- Ensure that the glass is secured correctly and that all retaining screws are in place.

Correct any faults found during the initial test.

Re-commission the appliance in accordance with Commissioning Procedures of these instructions.

Advise the customer of any remedial work undertaken.

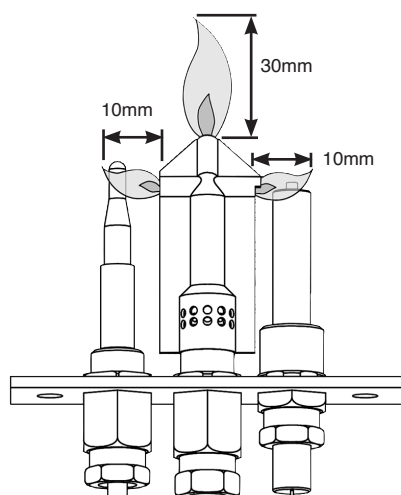

### ELECTRONIC CONTROL VALVE FAULT ANALYSIS

SYMPTOM	CAUSE	REMEDY
Frequent beeps for 3 seconds after operation request	Loose/damaged wire	Check interrupter block and wires
No ignition, no tone, motor turns slightly when operated	Receiver board damaged	Replace receiver
No pilot flame and control continues to spark	Thermocouple circuit wired incorrectly	Correct wiring
Pilot lights, control continues to spark, valve shuts down after 10 - 30 seconds	1. No spark at pilot burner 2. Loose/damaged wire	1. Rectify spark at pilot burner 2. Check interrupter and wires
Rear burner can not be turned off - valve can be heard to operate.	Faulty Solenoid Valve	Replace Solenoid Valve
Rear burner can not be turned off - no beep or noise from solenoid	1. Faulty wire/ wire not connected 2. Faulty receiver	1. Replace wire/ solenoid 2. Replace receiver

## FAULT FINDING CHARTS

### IGNITION FUNCTIONAL CHECK 1

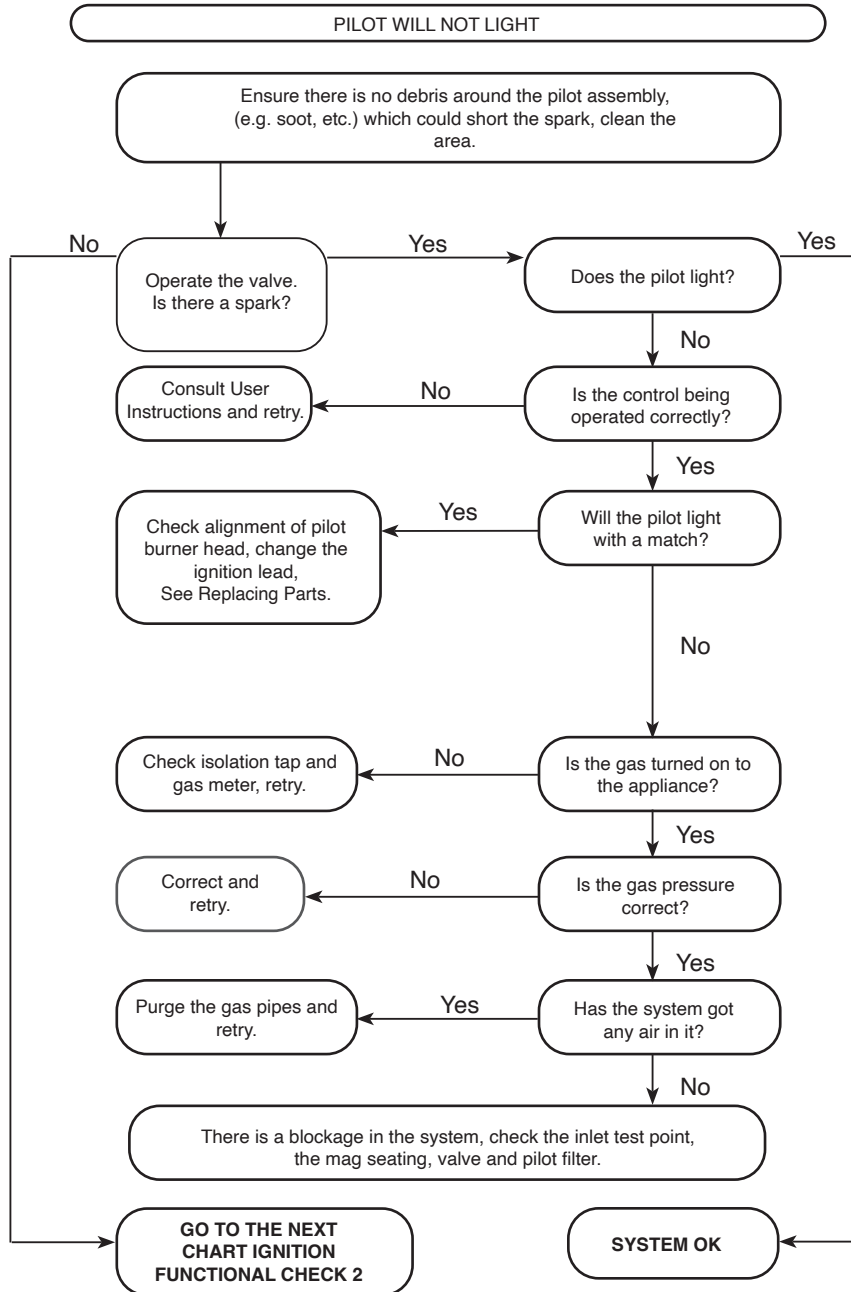

FAULT FINDING CHARTS

FLAME FAILURE FUNCTIONAL CHECK 3

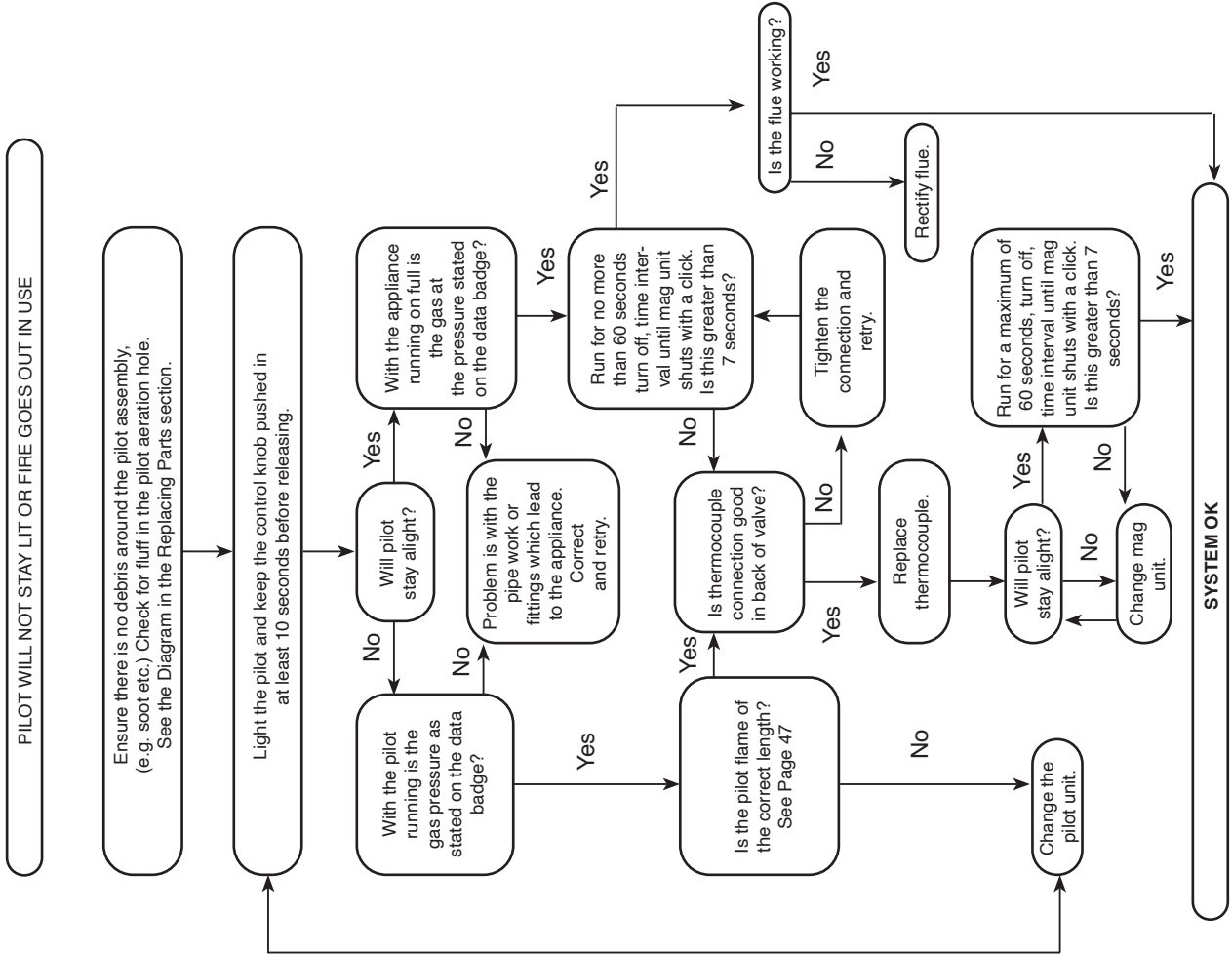

IGNITION FUNCTIONAL CHECK 2

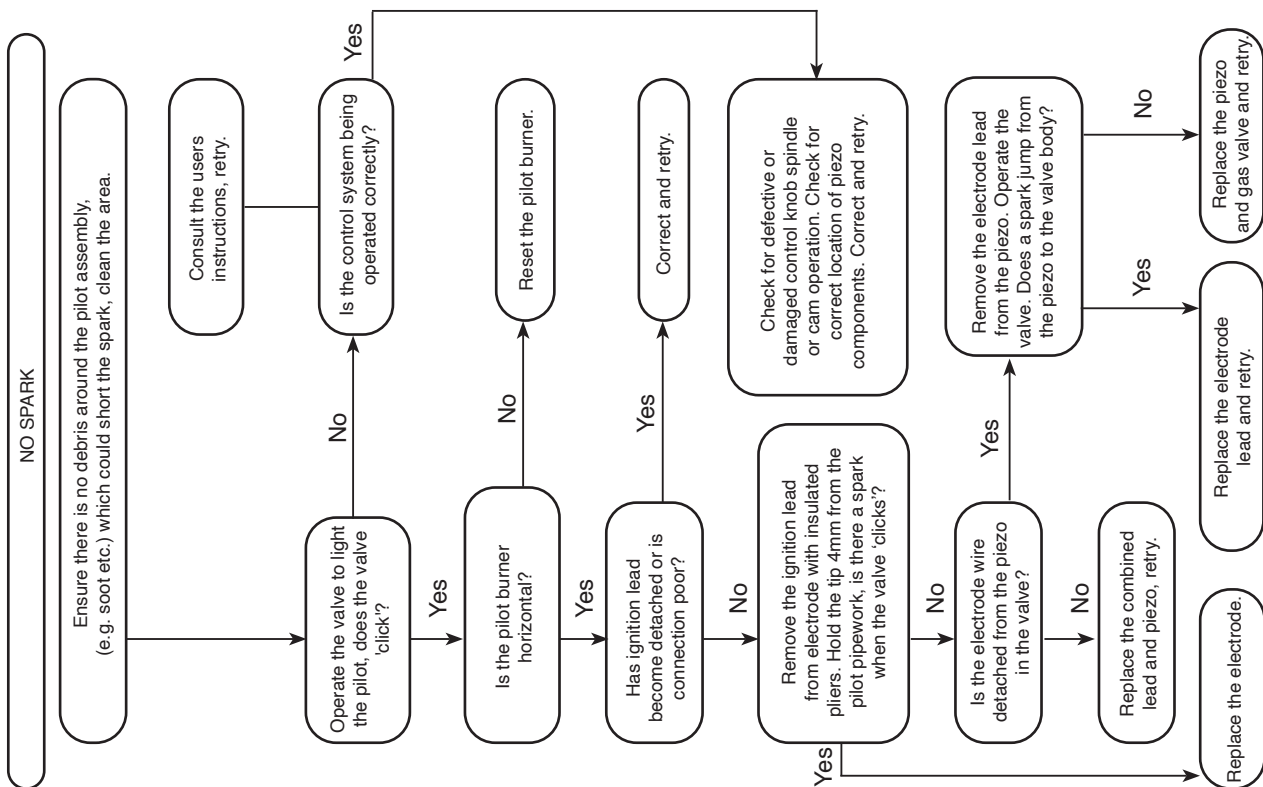

## REPLACING PARTS

### GENERAL

All main components can be replaced without removing the appliance from its installation.

**DISCONNECT MAINS ELECTRICAL SUPPLY AT THE ACCESSIBLE PLUG OR DEDICATED SWITCH BEFORE SERVICING THE APPLIANCE.**

**IT IS ESSENTIAL THAT THE GAS SUPPLY TO THE APPLIANCE IS TURNED OFF AT THE ISOLATION DEVICE BEFORE PROCEEDING FURTHER.**

It will be necessary to remove the burners and the fuel bed before any of the main components can be serviced.

The Power Module and the Wi-Fi Receiver can be serviced by removing the decorative trim and lower glass retaining bracket.



**DURING SERVICING OF THIS APPLIANCE IT MAY BE NECESSARY TO CUT CABLE TIES IN ORDER TO ACCESS AND REMOVE SOME OF THE PARTS. THESE MUST BE REPLACED WHEN REASSEMBLING THE APPLIANCE.**



**AFTER SERVICING ENSURE THAT ALL CONNECTIONS ARE REPLACED BEFORE REPLACING THE MESH TRAY.**

### REMOVING THE GLASS

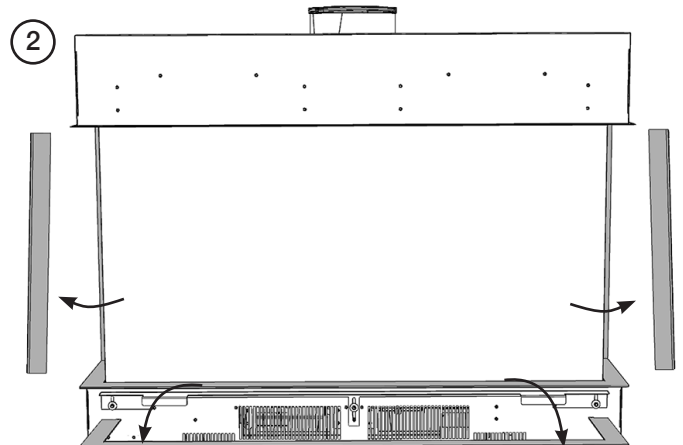
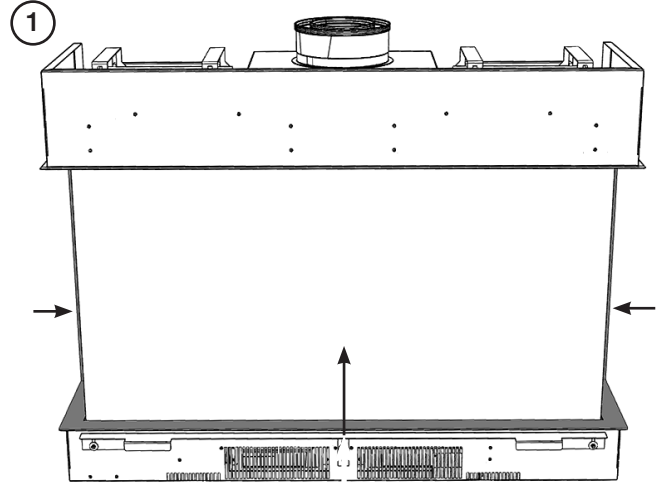

Loose the front glass clamps.

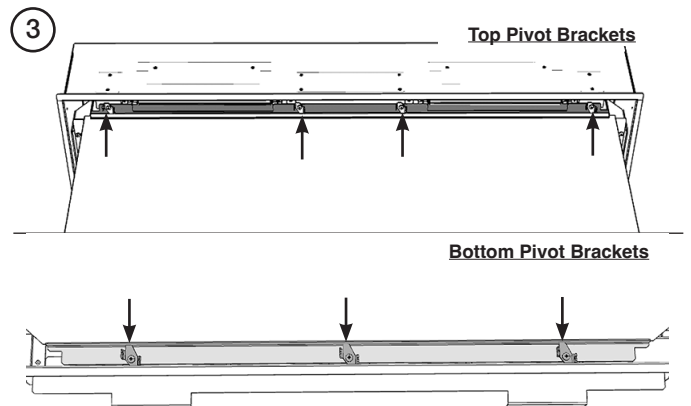

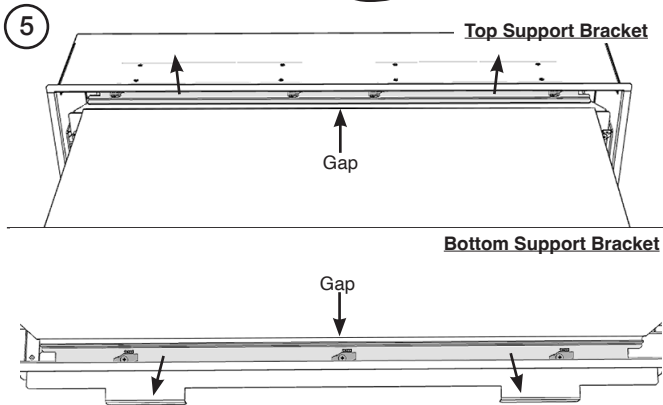
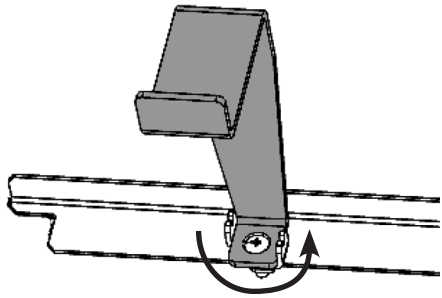
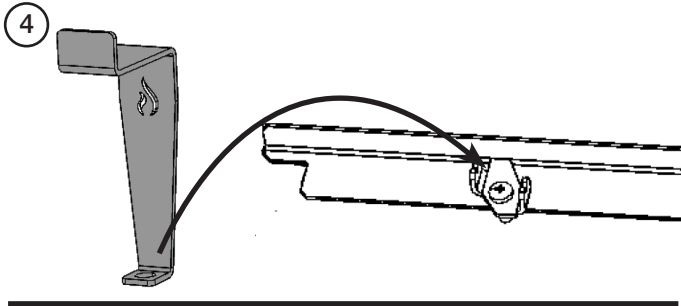

Lift out the front glass.

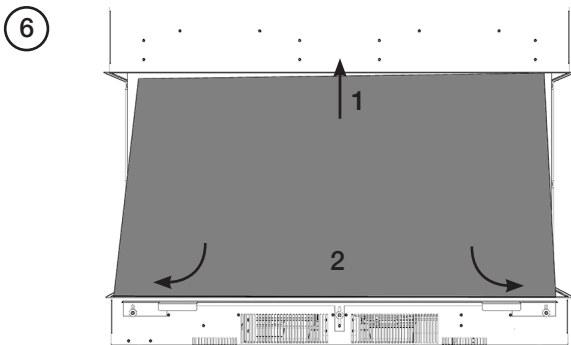

Loosen and slide side glass bracket.

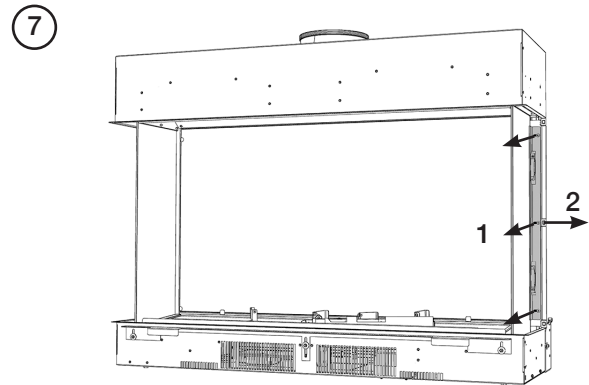

Repeat for the 2 upper Brackets and 2 lower Brackets.

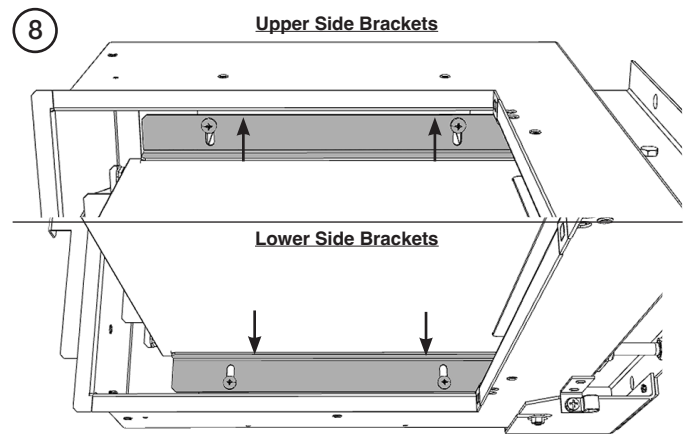

With the brackets disengaged, carefully slide the side glass panel forward, lift, and swing the bottom out to remove.

Place the glass carefully to one side.

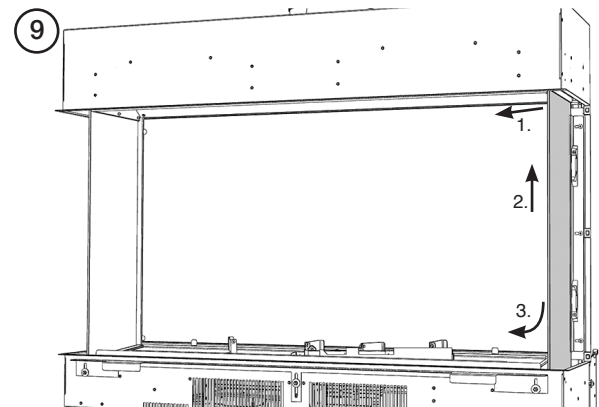

**i** The side glass does not need to be removed to service the appliance. It is recommended to leave the Side Glass in situ unless absolutely necessary.

The glass panel must be refitted to the appliance following cleaning or servicing.

To replace the glass panel, replace in reverse order.

### SETTING THE SIDE GLASS

Slide the glass carefully and firmly into position.

**ENSURE THAT ALL GLASS PANELS ARE FLUSH AND THAT THERE ARE NO GAPS BETWEEN PANELS.**

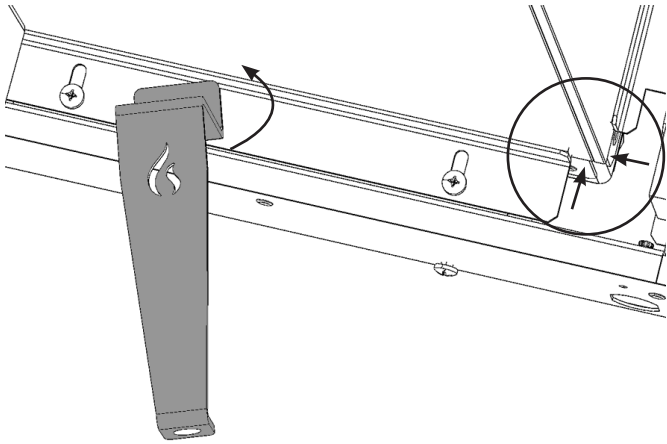

**Ensure that the brackets engage with the glass panel and the glass is pressed firmly into position.**

Tighten the bracket screws.



**UNDER NO CIRCUMSTANCES SHOULD THE APPLIANCE BE USED IF ANY OF THE GLASS PANELS ARE LOOSE, DAMAGED, OR MISSING.**

Replace the lower and side trim.

## REMOVING THE FUEL EFFECT

The fuel effect consists of 6 different components.

To avoid damage Logs A, B, C, F and M should be removed in the following order and placed on a dry, clean surface.

Remove Log M from the groove in Log A.

Remove Log B from the Log Burner.

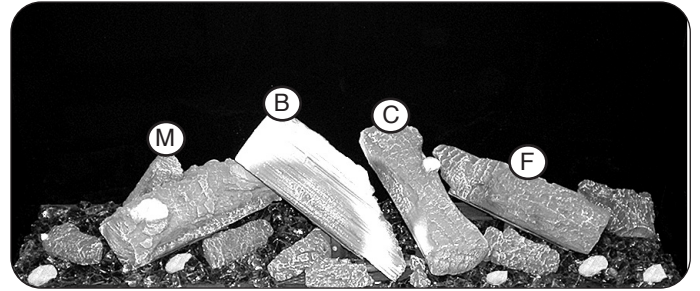

Remove Log C & F from the Log Burners.

Slide Log A backwards, from under the centre Log Burner, to remove.



Remove the remaining components:

1. Large Embers J & H
2. Ember G (x3) & Ember L
3. Shale Effect
4. Amber Effect

**Keep each component separate for ease of replacing.**

**When replacing the fuel effects see Installation Instructions Section for layout instructions.**

## REMOVING THE LOG BURNERS AND MAIN CONTROL ASSEMBLY

Remove the Front Glass.

Remove the Fuel Effect.

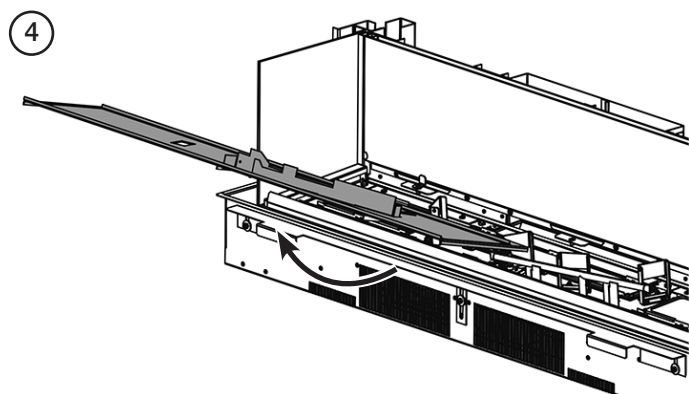
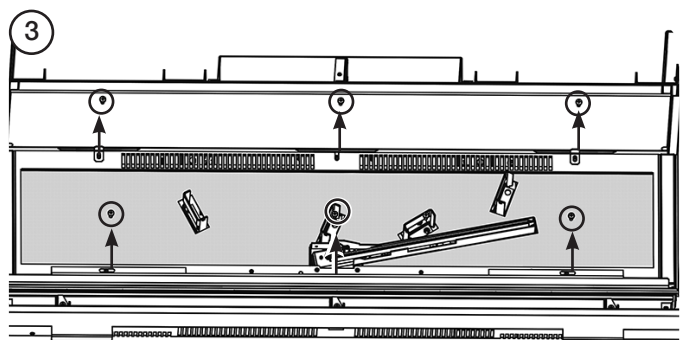
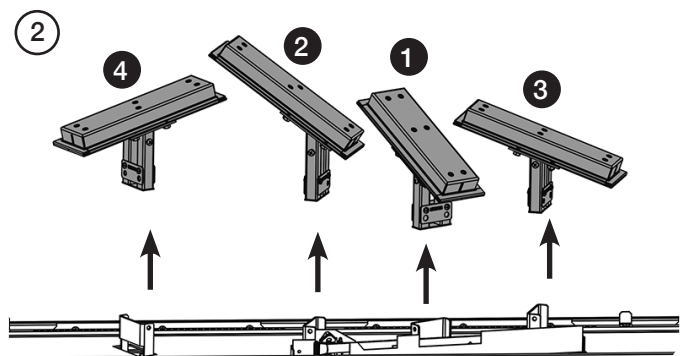
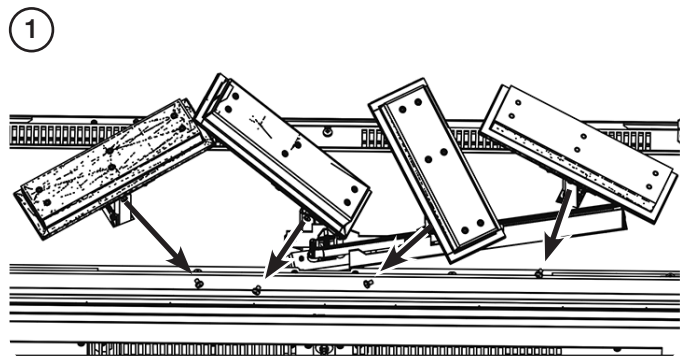

WHEN REPLACING THE MESH TRAY TAKE CARE NOT TO DAMAGE THE LOG BURNER BRACKETS, PILOT AND CROSS LIGHTER. REPLACE THE FRONT SCREWS FIRST BEFORE TIGHTENING THE REAR SCREWS.

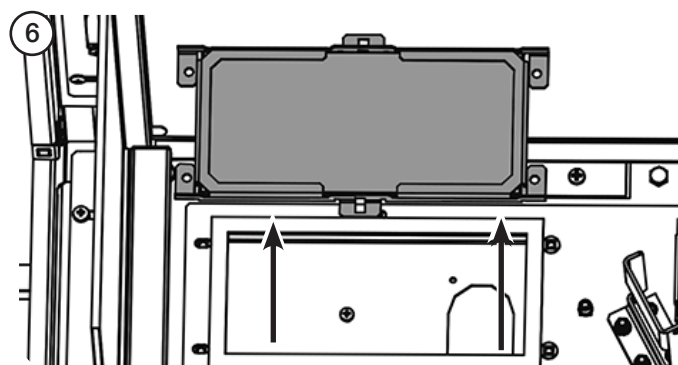
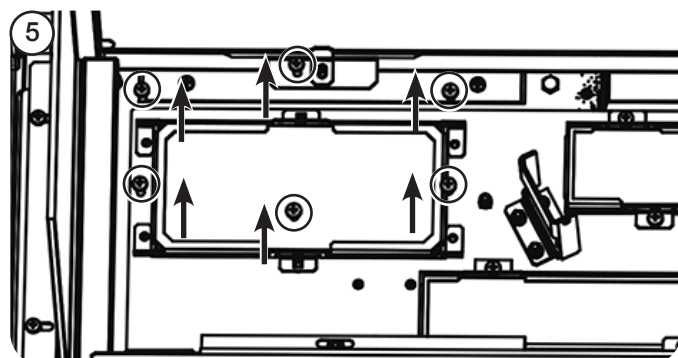

Turn the gas supply off at the isolation device.

### HAVE YOU ISOLATED THE GAS SUPPLY?

Disconnect the isolating device from the appliance inlet pipe (A) to isolate the gas supply.

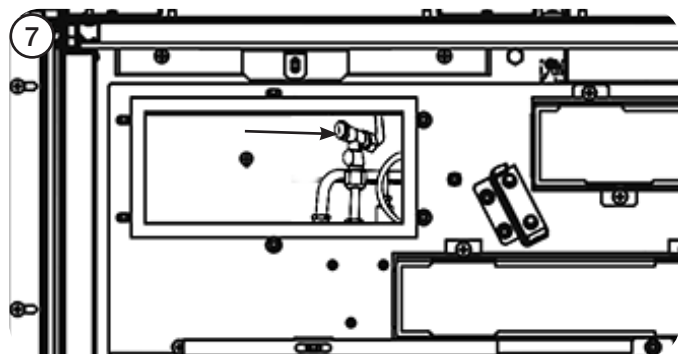

Remove the remaining screws securing the Main Control Assembly to the firebox.

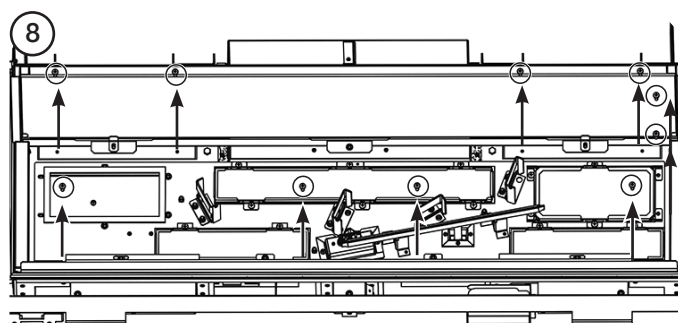

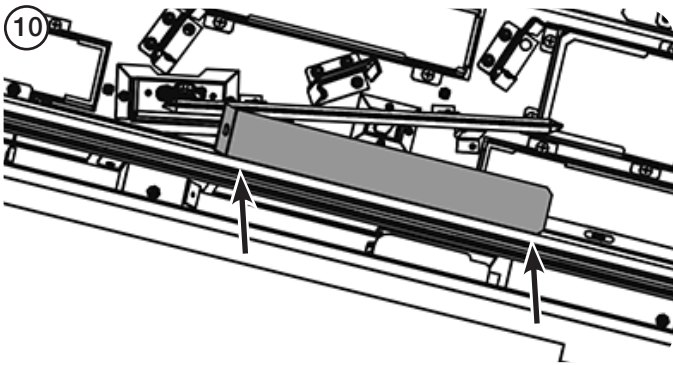
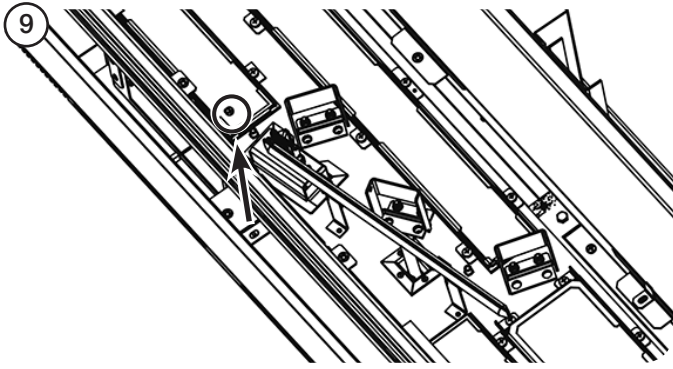

Disconnect the Mains Lead Plug, the LED leads and the receiver lead from the Module and the Wi-Fi box (if installed).  
**DO NOT REMOVE THE WIRES FROM THE PLUG.**

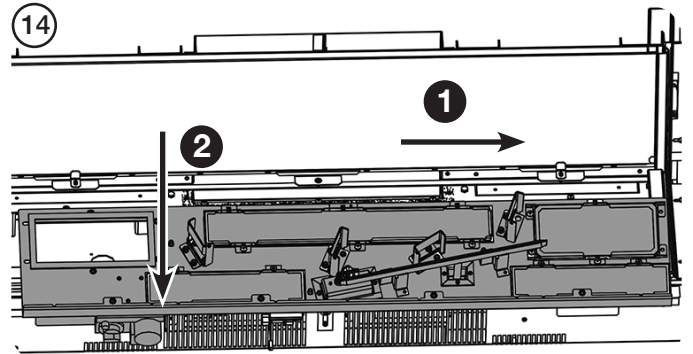
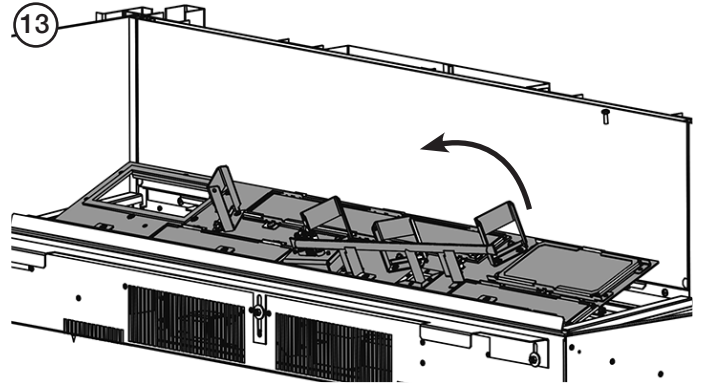
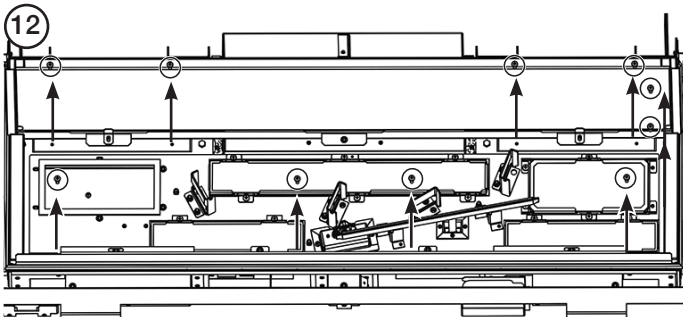
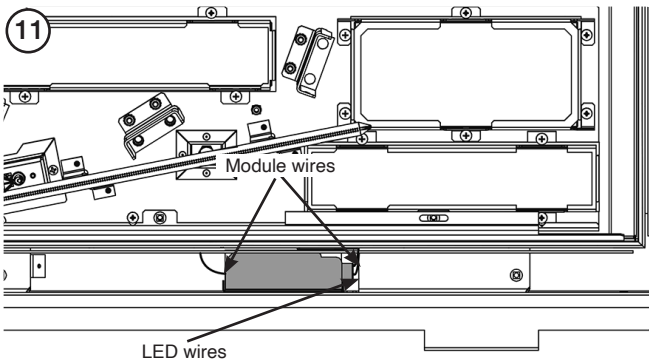

NOTE: Take care not to catch any loose wiring previously disconnected against the front edge of the firebox.  
 Replace in reverse order.



**AFTER SERVICING ENSURE THAT ALL CONNECTIONS ARE REPLACED BEFORE REPLACING THE MESH TRAY.**

## REPLACING THE LED CIRCUIT

There are 5 LED boards, which can be replaced individually.

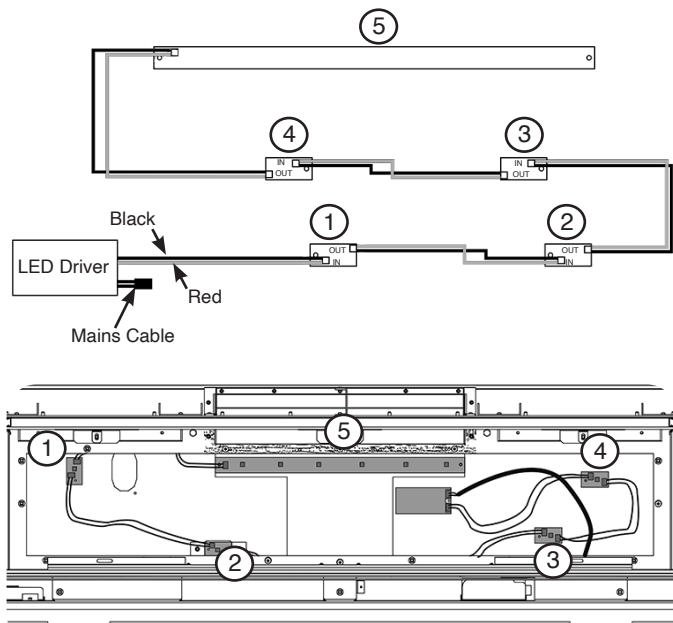

**! THE LEDS ARE FRAGILE. HANDLE WITH CARE. ONLY HOLD THE LED BOARDS BY THE EDGES TO AVOID CONTACT WITH THE TOP OF THE LED'S.**

**AVOID CATCHING ANY DELICATE WIRES WHEN REPLACING THE SCREWS.**

Remove the Log Burners, Fuel effect, and Mesh tray.

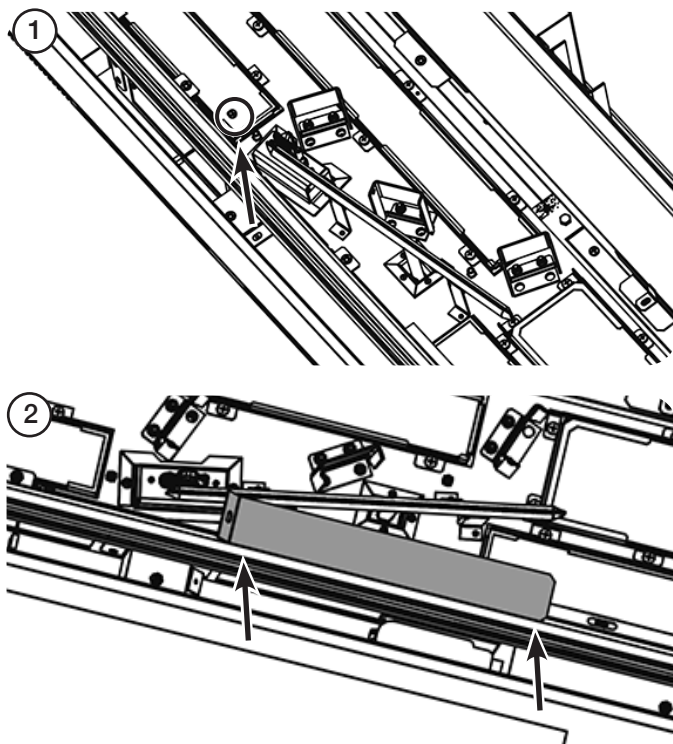

Disconnect the LED Mains Lead Plug from the Module.

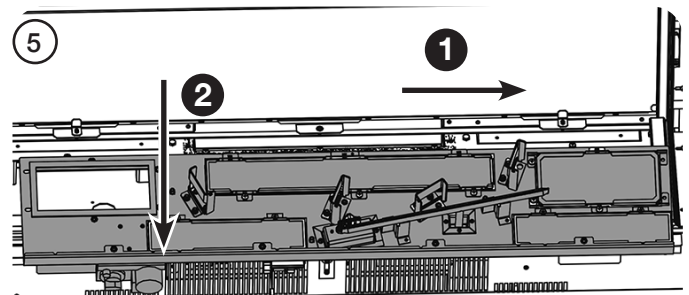
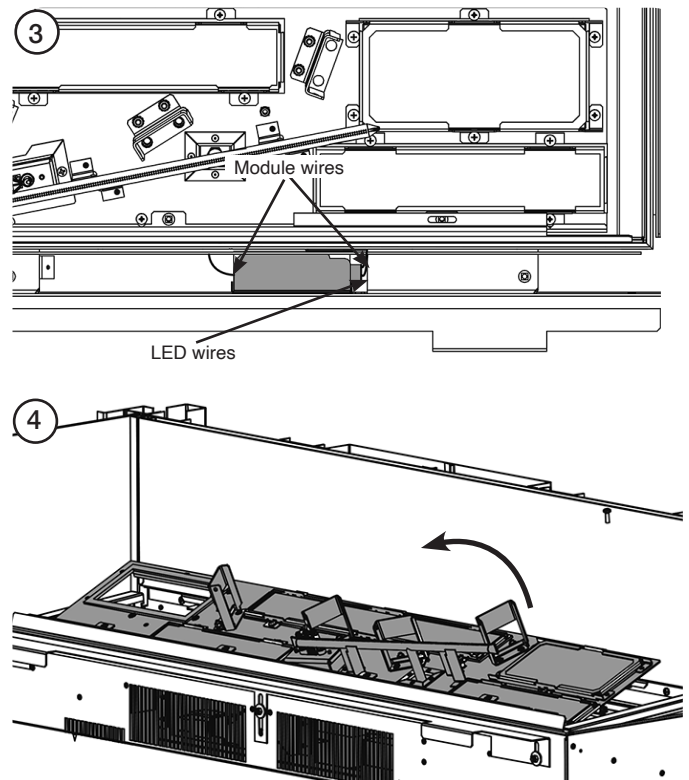

The LED circuit consists of three components, which can be individually changed, these are:

- Front LED Boards.
- Rear LED Bar.
- Driver.

### LED BOARDS

NOTE: Each board has the wiring direction marked as IN or OUT on each end to ensure the replacement boards are wired correctly. Repeat for each front LED board.

### LED DRIVER

Remove the screw in the center of the Driver lip.

Carefully lift the Driver (with cables) off the control assembly to remove.

Replace in reverse order ensuring the components are in the correct configuration.

**! ENSURE NO WIRES ARE TRAPPED WHEN REPLACING THE COMPONENTS.**

## REPLACING THE MODULE

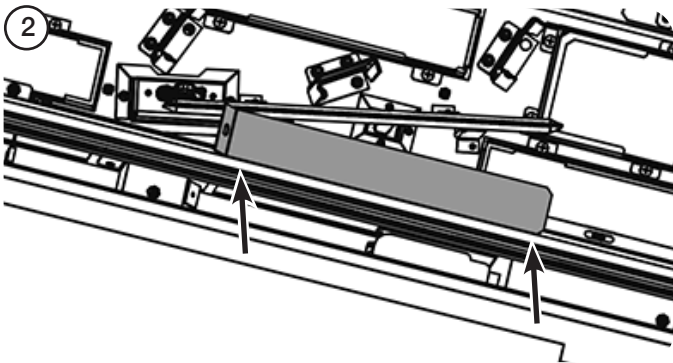
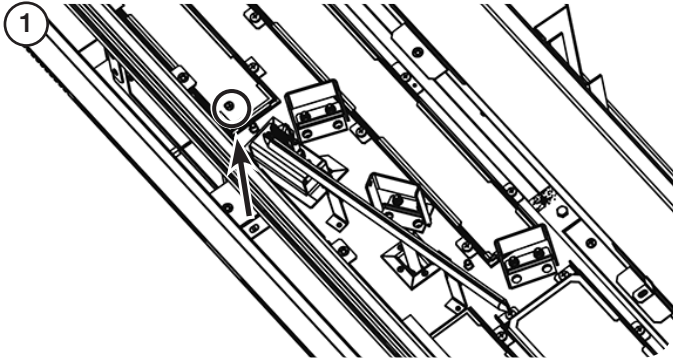

Disconnect the LED Mains Lead Plug from the Module.

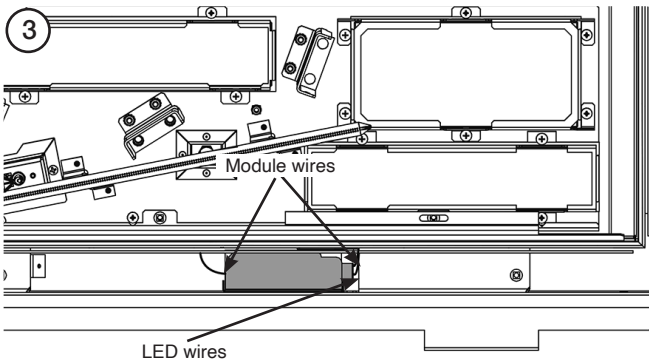

Disconnect the LED plug and Mains lead from the module.

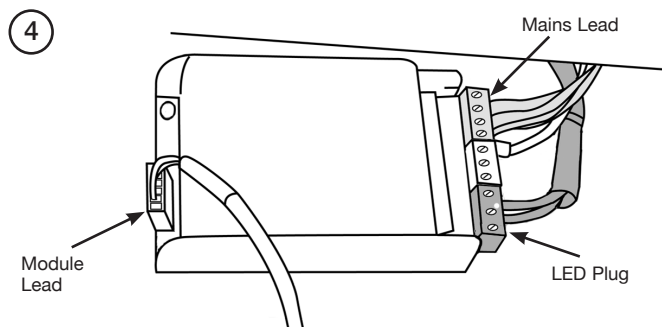

Disconnect the Module Lead.

The Module can now be removed.

Replace in reverse order.

## PILOT UNIT ASSEMBLY

Turn off the gas supply at the isolating device.

Remove the Log Burners and Main Control Assembly.

The pilot bracket can be accessed from the underside of the Main Control Assembly.



**IMPORTANT: UNDER THE TERMS OF THE EXTENDED WARRANTY IT WILL BE COMPULSORY TO CHANGE THE COMPLETE PILOT UNIT ON THIS APPLIANCE IN YEARS 2, 4 AND 6.**

Undo pilot pipe from the control valve, see Arrow A.

Remove the thermocouple from the interrupter block, See Arrow B.

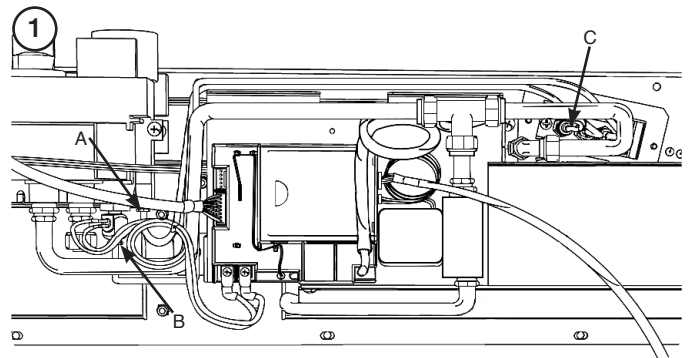

Remove the ignition lead from the electrode, see Arrow C.

Undo the 2 retaining screws from pilot unit bracket.

The pilot bracket can now be withdrawn from its cradle.

The pilot assembly consists of three components, which can be individually changed, these are:

- Electrode.
- Pilot Injector.
- Thermocouple.

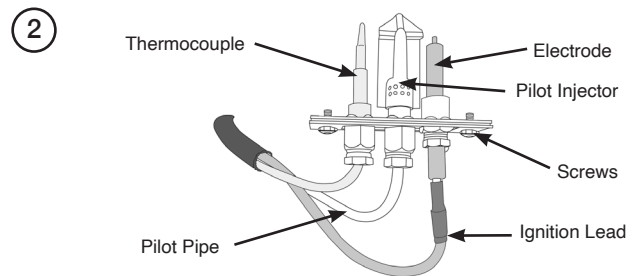

## ELECTRODE

Pull the ignition lead off the electrode and undo the retaining nut, see arrow A.

3

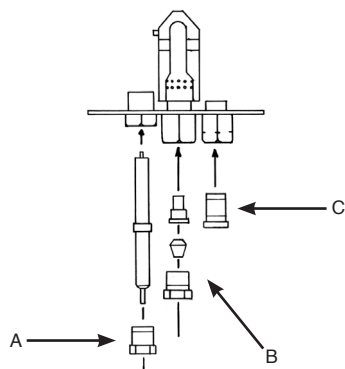

Replace with a new electrode. Do not over-tighten the nut; this could break the component.

Replace the ignition lead.

## PILOT INJECTOR

With the pilot assembly removed, undo the nut to drop the injector out from the burner, see Arrow B.

## THERMOCOUPLE

Undo the brass nut to remove the thermocouple from the pilot burner unit, see Arrow C.

## IGNITION LEAD

Unplug the Ignition lead from the control box.

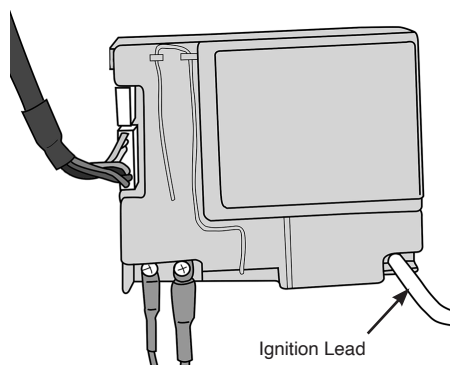

Carefully cut cable ties from the vidaflex and disconnect the lead from the electrode.

**IMPORTANT** Ensure not to cut the cables.

**NOTE:** When replacing, ensure the ignition lead does not run across the control box.

## GAS VALVE

To change the gas valve:

Remove the Log Burners and Main Control Assembly.

Disconnect the Gas Inlet Pipe, Arrow A.

Disconnect the Gas Outlet Pipe, Arrow B.

Disconnect the Pilot Pipe, Arrow C.

Disconnect the Thermocouple, Thermocurrent Wires and the Interrupter Block, Arrow D.

Remove the Eight Wire Loom, Arrow E.

There is an access hole above the cable plug on the valve. Insert a small screwdriver to release the locking tab.

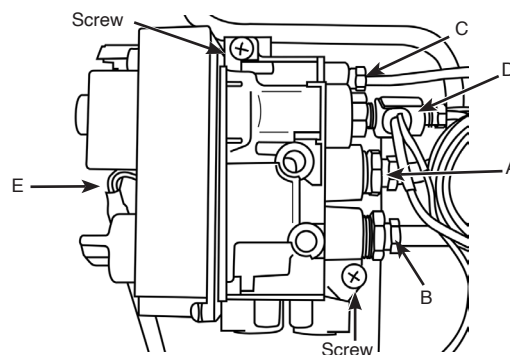

Remove the 2 screws securing the Valve to the support bracket and withdraw the Valve.

Replace in reverse order and check for leaks.

## MAGNETIC SAFETY VALVE

Remove the Log Burners and Main Control Assembly.

Undo the Thermocouple from the Interrupter Block and remove the 2 Interrupter Leads.

Unscrew the Interrupter Block from the back of the Valve.

Undo the silver Magnetic Valve retaining nut on the back of the Valve.

Gently tap out the Mag Valve.

Replace with a new unit.

Reassemble in reverse order ensuring that the interrupter leads are connected correctly with the blue tag lead furthest away from the gas valve body.

Check for leaks.

## CONTROL BOX

To replace the Control Box first remove the Main Control Assembly.

Cut the cable tie holding the Ignition lead and the Thermocurrent cables.

Disconnect the Module and Solenoid leads from the Control Box.

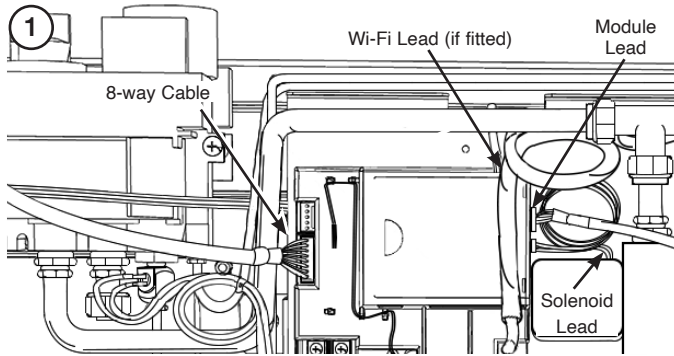

If fitted disconnect the Wi-Fi Lead.

Note: The Wi-Fi lead is loose when removed, ensure the lead is not misplaced whilst servicing.

Remove the Ignition Lead. The Control Box is held on by Velcro pads.

Remove the 2 screws to remove the 2 Interrupter Leads.

Remove the 8 way cable from the Control Box.

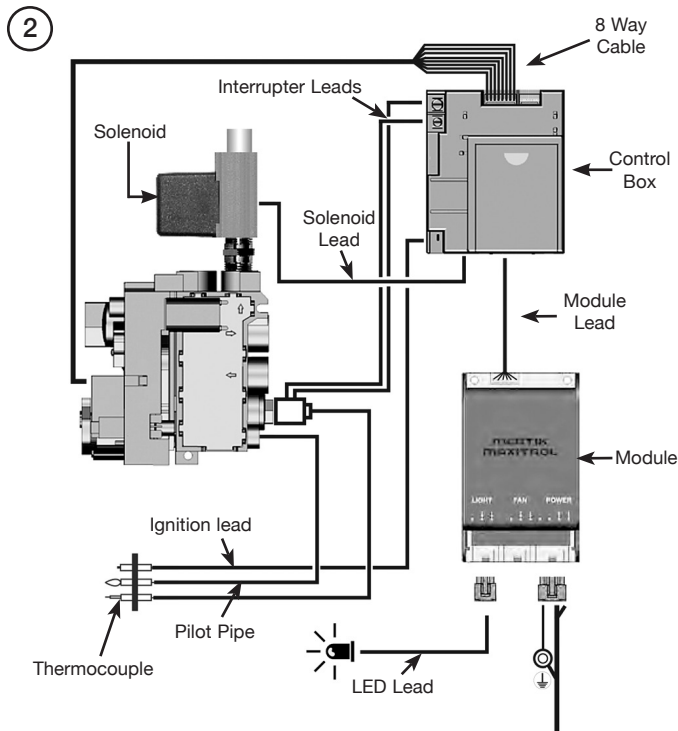

Replace in reverse order.

After replacing the Control Box ensure that all cable ties and connections are refitted.

After replacing the Control Box you will need to reprogram the handset.

- Press and hold the reset button on the control box until you hear two signals. After the second longer signal:
- Release the reset button and within 20 seconds:
- Press the DOWN button on the handset until you hear two additional short signals confirming the new code is set. If there is a single long signal the code learning sequence has failed or the wiring is incorrect.

**Note: When pressing the DOWN button on the handset if two beeps are not heard:**

- Release the DOWN button and CONN will be displayed on the handset screen. An 8 second count will start on the handset screen followed by two short beeps confirming the new code is set. If there is a single long signal the code learning sequence has failed or the wiring is incorrect.

## FUEL BED INJECTORS

This appliance has 8 Fuel Bed Injectors.  
NOTE: The injectors are not identical.

**TO ENSURE CORRECT ASSEMBLY REPLACE EACH INJECTOR INDIVIDUALLY.**

Remove the Log Burners and Mesh Tray.

Remove the 2 nuts and lock washers from each Burner Bracket.

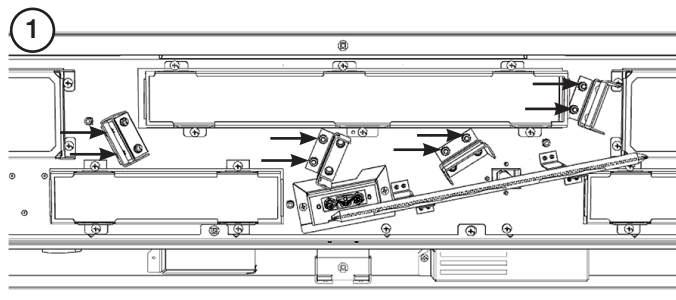

Remove the Brackets.

Remove the Gasket.

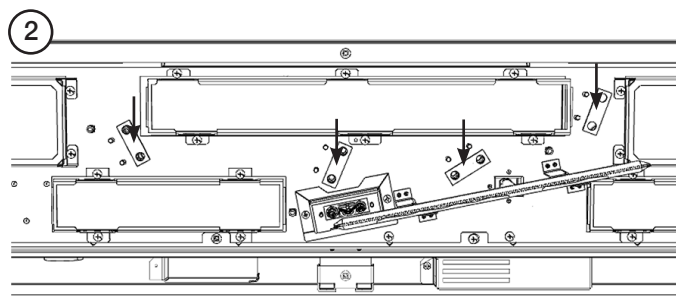

Undo the Injectors individually.

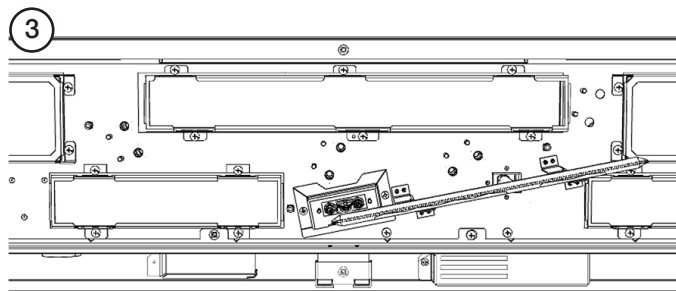

Replace with the correct size Injector.  
See table on Page 15.  
NOTE: DO NOT OVERTIGHTEN.

Use thread sealant Loctite 572 when replacing Injectors.

Repeat for the remaining Injectors.

Check for leaks.

## CROSS LIGHTING INJECTOR

Remove the Log Burners and Main Control Assembly.

Turn the Main Control Assembly over to access the components on the underside.

Remove the injector pipe by loosening the two nuts.

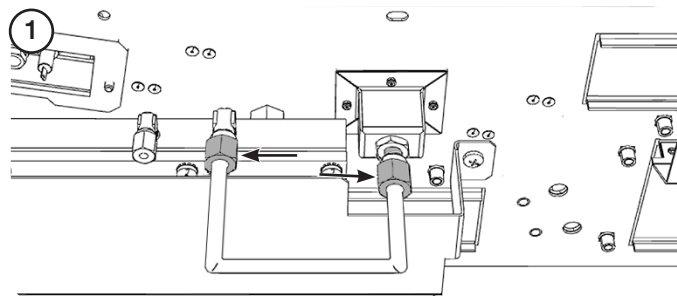

Undo the nut from the Cross Lighter.

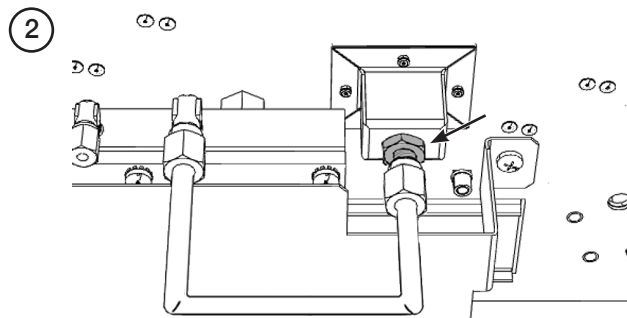

Turn the Main Control Assembly over.

Withdraw the Cross Lighting bar from the Control Assembly.  
The Injector is screwed into the bottom of the bar.

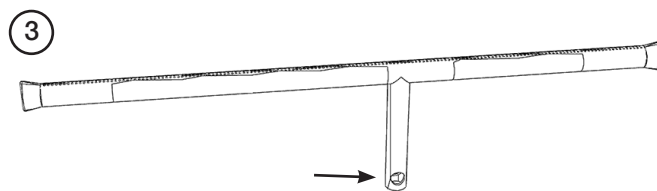

Replace with the correct size Injector and refit all components in the reverse order.  
Ensure the left and right hand sides of the Burner engages in the bracket slots.  
NOTE: The LH bracket is part of the Pilot bracket.

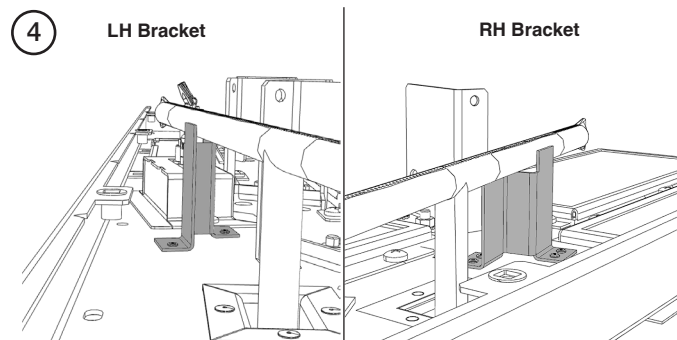

Check for leaks.

## LATCHING SOLENOID

Remove the Main Control Assembly.

Remove the cradle holding the rear LED's to access the pipe work for the solenoid.

Undo the 3 nuts shown and free the solenoid from the pipe work.

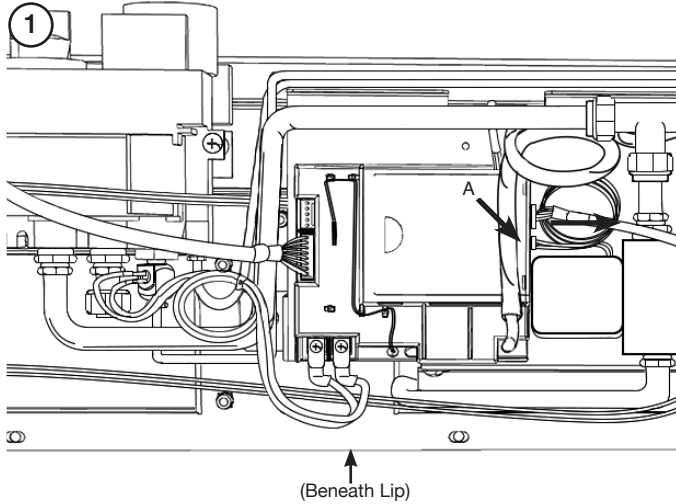

Remove the Solenoid plug from the Control Box, Arrow A.

Cut the cable tie. **NOTE the orientation of the cables.**

Replace in reverse order.

Check for leaks.

**Ensure that the cable ties are replaced.**

## LINERS

Remove the Front Glass, Fuel Effect, and Main burners.

## SIDE PANELS - 2 SIDED INSTALLATION

The following instructions assume a right-handed installation. If fitting a left-handed installation the instructions are still correct, however, the images may not wholly reflect the installation in question.

If fitted, remove the decorative trims.

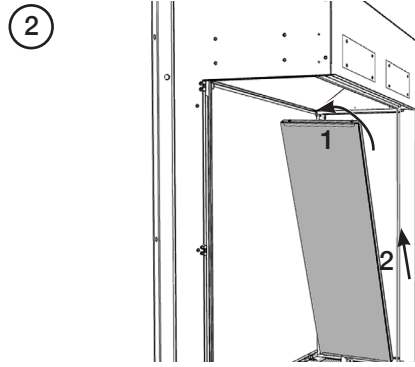
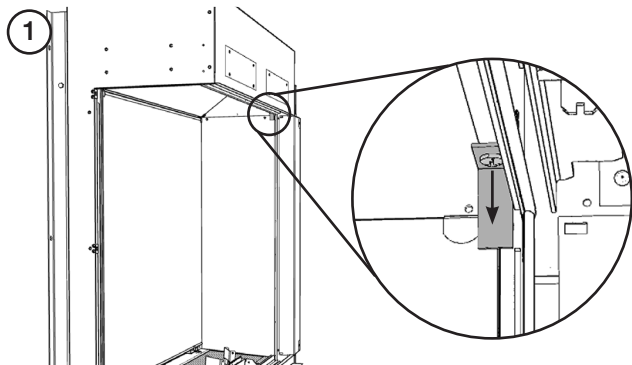

## BACK PANEL

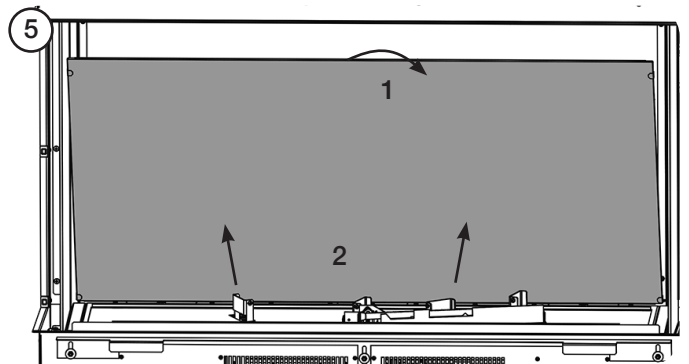
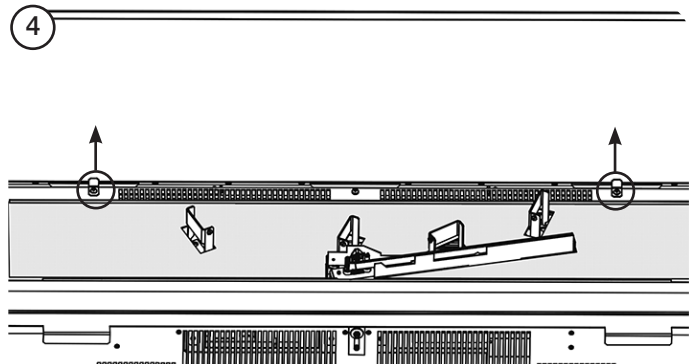
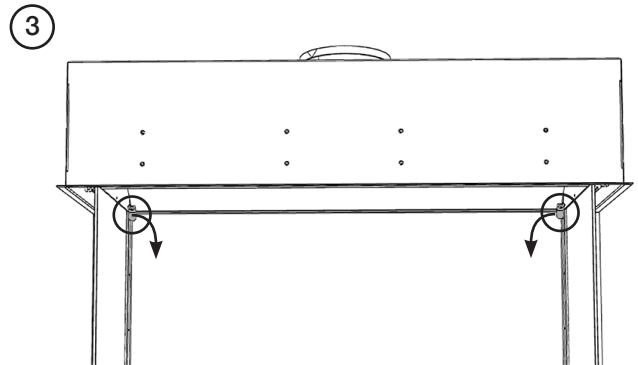

To replace the Liners reverse these procedures. Ensure no amber glass or black shale has fallen onto the side liner infill or liner support brackets.

## BAFFLE

Remove the Front Glass, Fuel Effect, and Main burners.

Remove the Rear Liner and Side Liner (if applicable).

The Baffle is held in position by 10 screws.

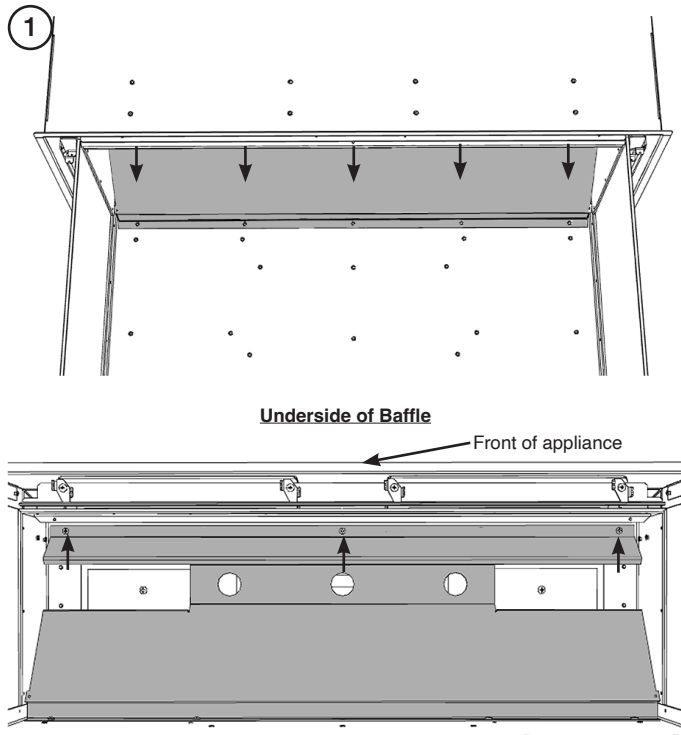

Replace in reverse order.

## REPLACING THE POWER CABLE

**BEFORE UNDERTAKING ANY WORK SWITCH OFF THE APPLIANCE AND ISOLATE THE POWER SUPPLY ENSURING THERE IS NO POWER TO THE APPLIANCE.**

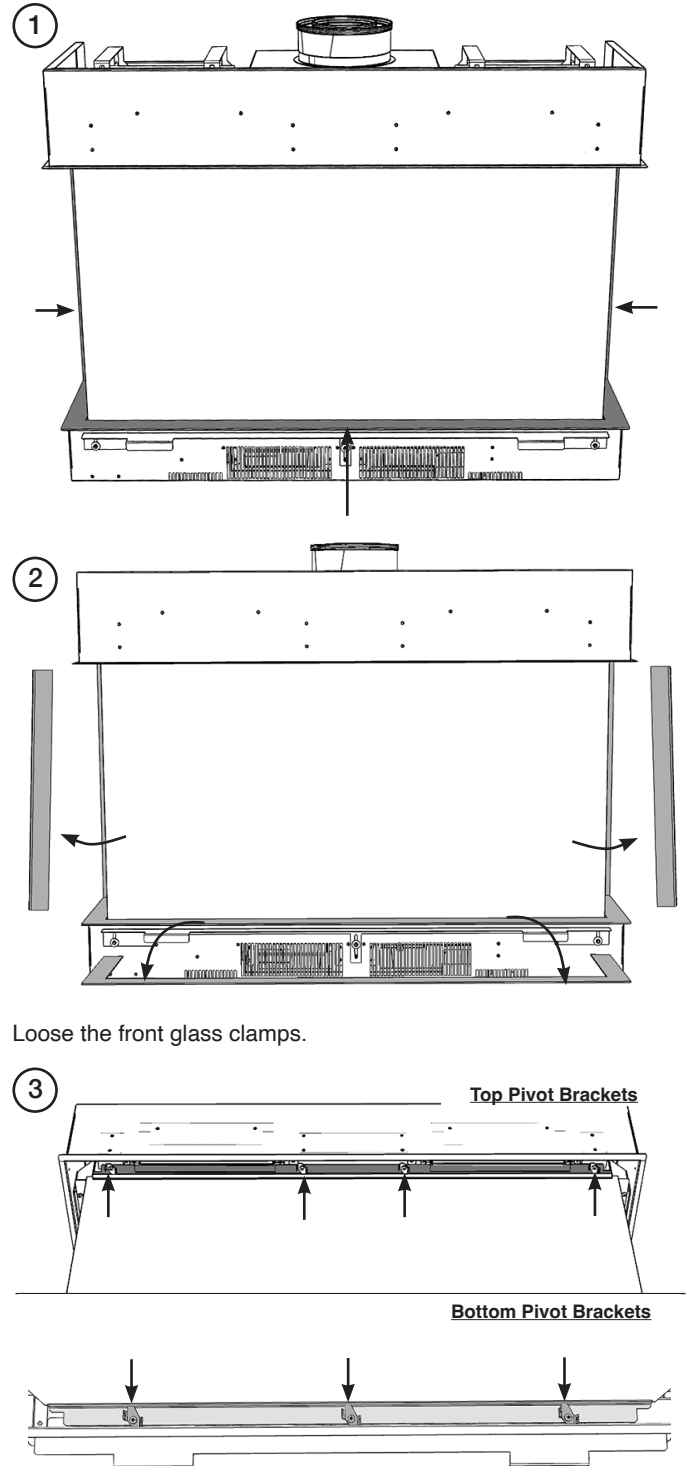

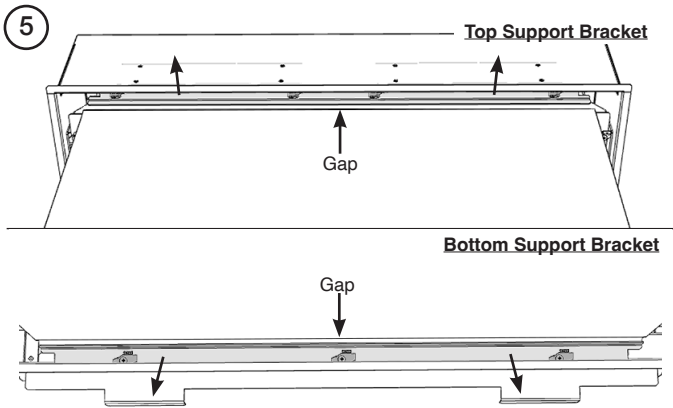
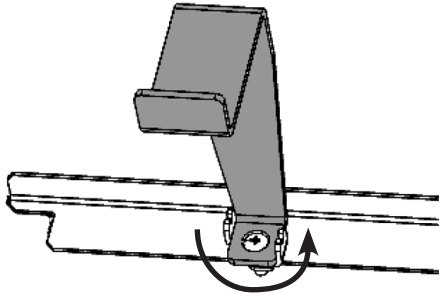
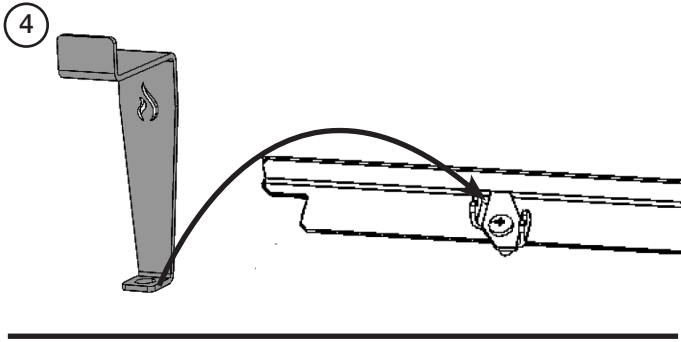

Lift out the front glass.

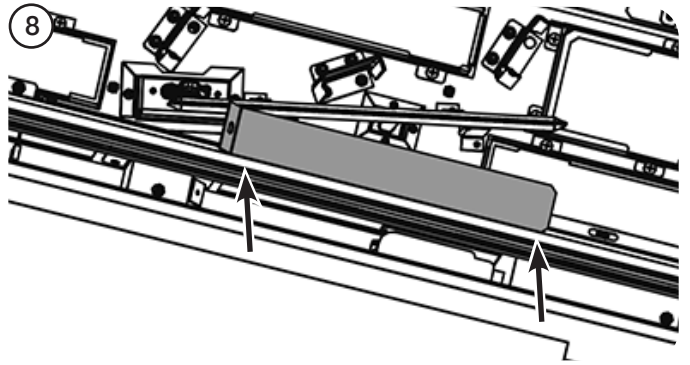
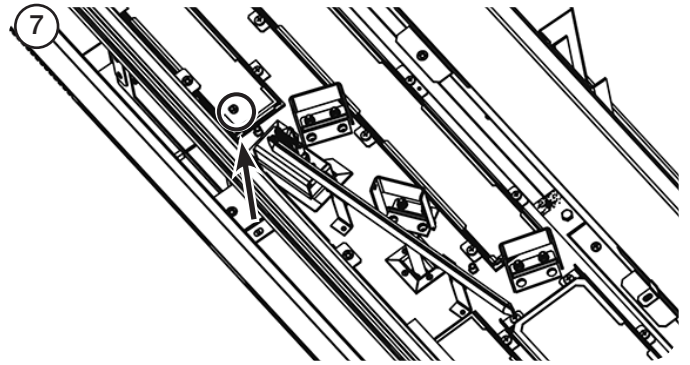
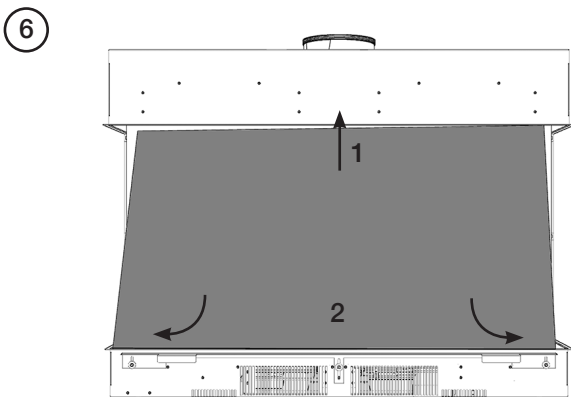

Disconnect the LED Mains Lead Plug from the Module.

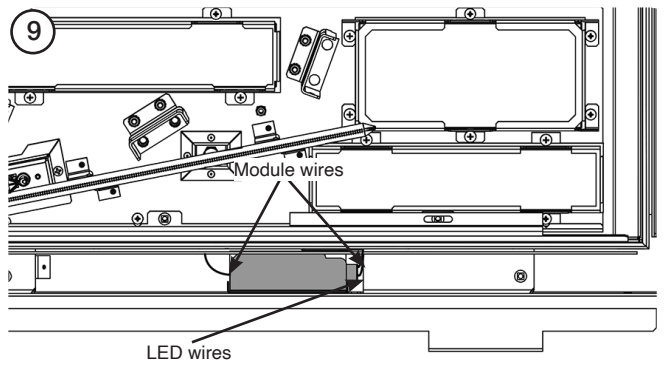

Disconnect the LED plug and Mains lead from the module.

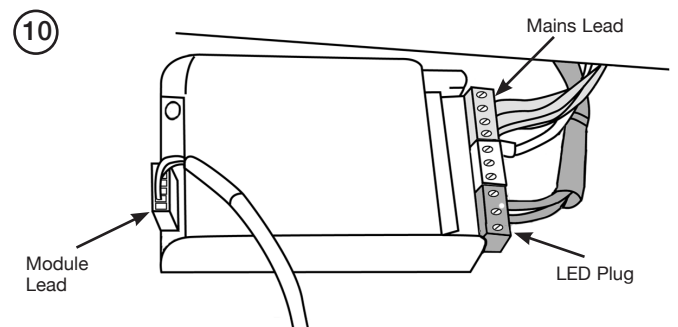

Disconnect the 3 cables from the Power Module, Arrow A.

NOTE THE CONFIGURATION OF THE WIRES.

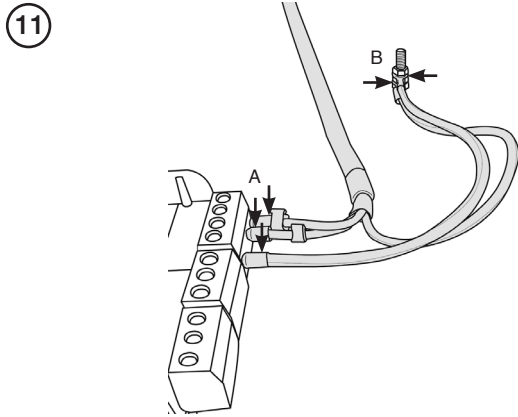

Remove the nuts from the Earth stud and remove the two Ring Terminals, Arrow B.

Loosen the locking screw securing the Power Cable in place.

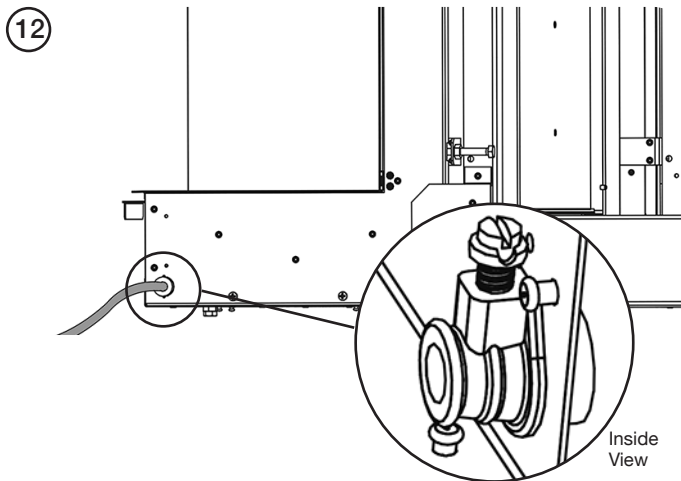

Withdraw the old cable.

Fit the new cable in reverse order ensuring it is rewired in the original configuration.

## SPARE PARTS - MAIN ASSEMBLY

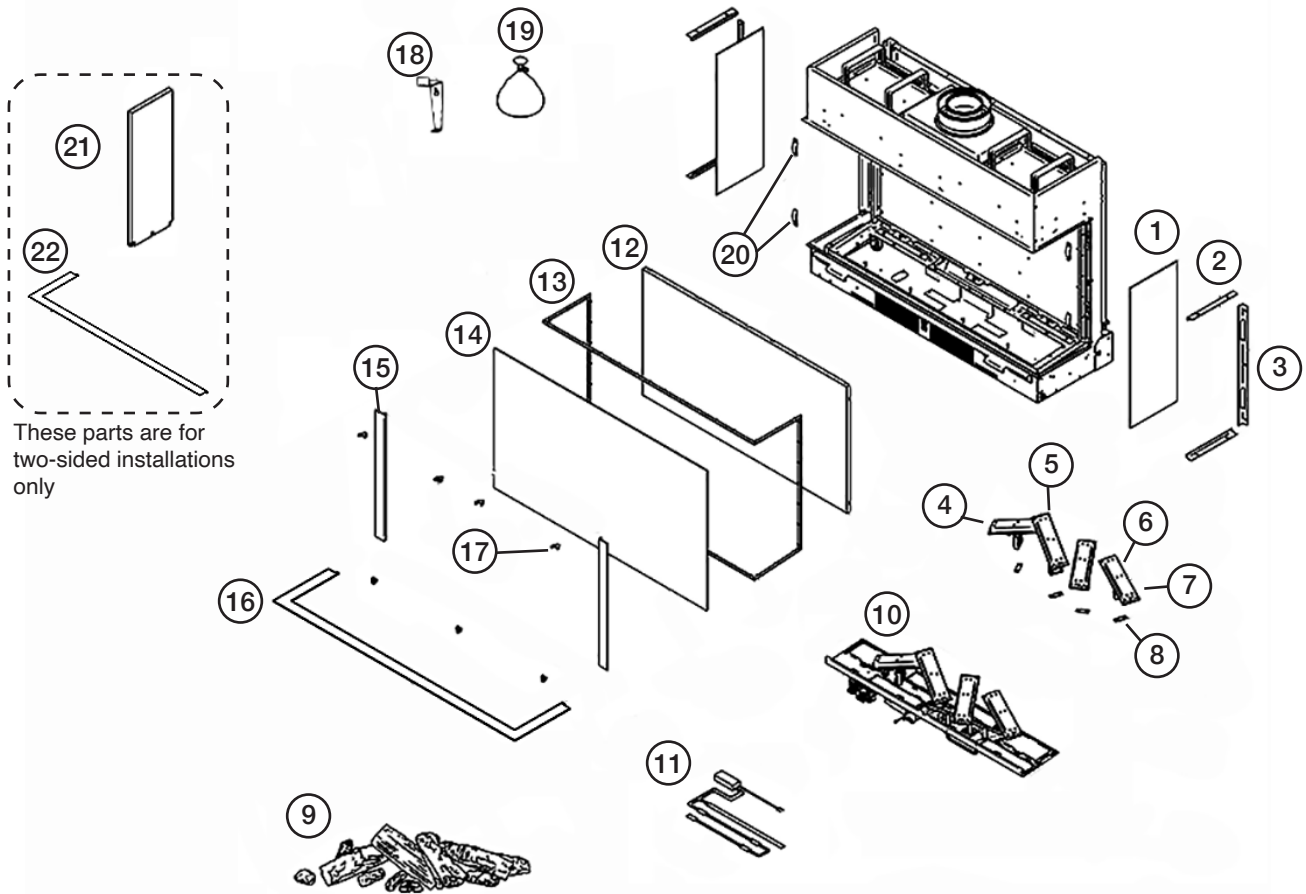

NO.	COMPONENT	PART CODE		QTY.
		NG	LPG	
1	Side Viewing Glass	CE2058		2
2	Side Glass Retainer	GZ15608		4
3	Rear Glass Retainer	GZ15834		2
4	1st LH Burner	GZ16420	GZ16436	1
5	2nd Central Burner Assembly	GZ16421	GZ16437	1
6	3rd RH Burner Assembly	GZ16422	GZ16438	1
7	4th RH Burner Assembly	GZ16434	GZ16439	1
8	Injector Seal	CE1738		4
9	Ceramic Log Set	CE1923		1
10	Engine Assembly	GZ16134N	GZ16134P	1
11	LED Lights & Wiring Loom	EL0743		1
12	Black Glass Rear Panel	991-056		1
	Ledgestone Rear Panel	991-388		1
	Brick Effect Rear Panel	991-247		1
13	Ropeseal	FA0783		1
14	Front Viewing Glass	CE2057		1

NO.	COMPONENT	PART CODE		QTY.
		NG	LPG	
15	Side/Rear Trim	GZ15791		2
16	Base Trim	GZ15790		1
17	Cam Lock Bracket	GZ15061		7
18	Hand Tool	GZ16547		1
19	Amber Crushed Glass	CE1737		2
20	Spring Clip	FA0771		4
21	Black Glass Side Assembly	991-262		1
	Ledgestone Side Assembly	991-129		1
	Brick Effect Side Assembly	991-011		1
22	Base Trim (Corner Install)	GZ15792		1



Due to continual technical improvements please check online or with your Gazco retailer for the most up to date parts lists.

Only use Genuine Gazco spares when servicing your appliance.

All of our essential spare parts and consumable items are available to purchase from our webshop at [www.gazcospares.com](http://www.gazcospares.com).

## REFLEX 105 CONTROL ASSEMBLY

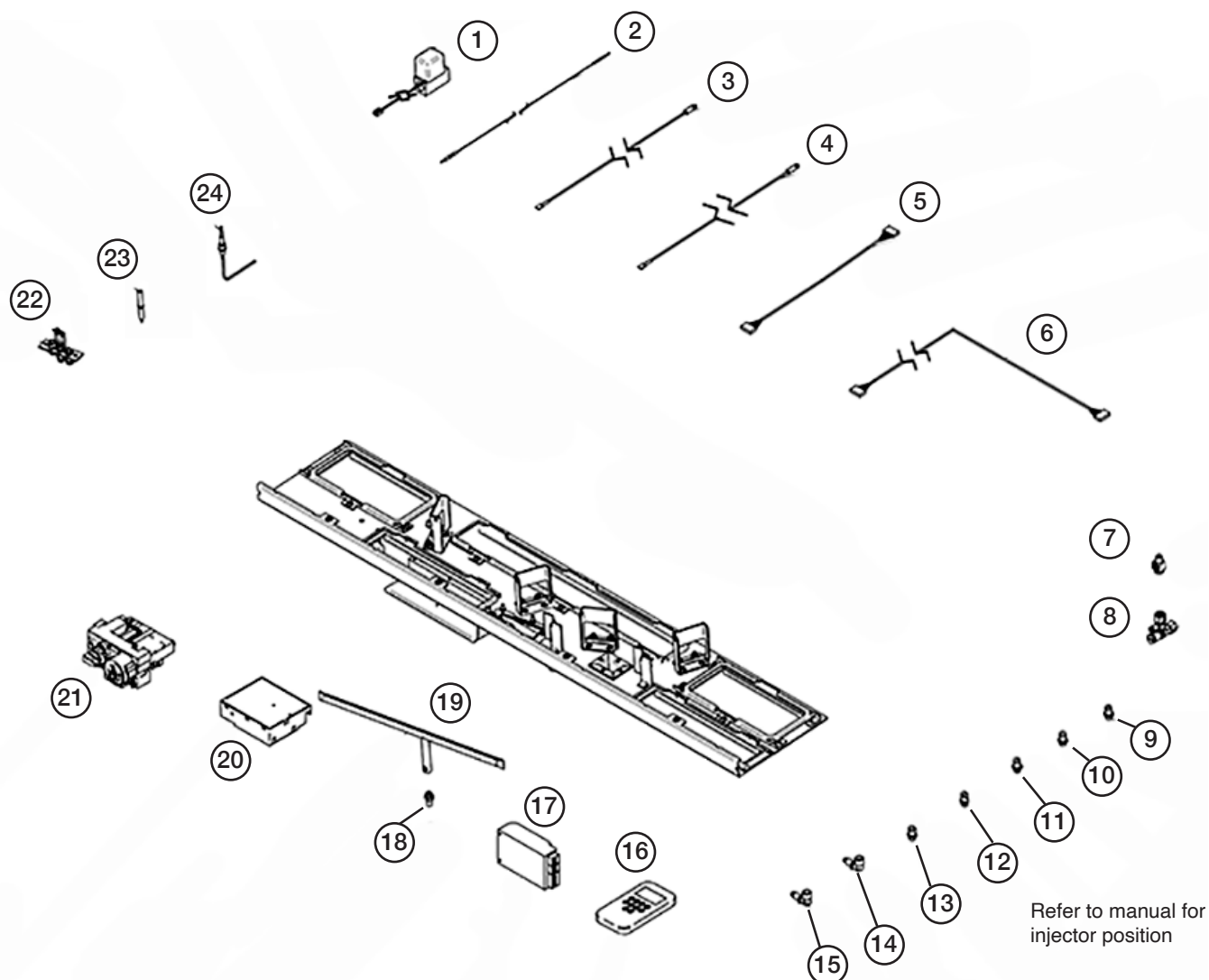

NO.	COMPONENT	PART CODE		QTY.
		NATURAL GAS	LPG	
1	Latching Solenoid Valve	EL0563		1
2	Ignition Lead	GC0125		1
3	Thermocurrent Cable	GC0126		1
4	Thermocurrent Cable	EL0590		1
5	Metric Module Cable	EL0566		1
6	360mm Connection Cable	GC0133		1
7	Thermocouple Interrupter	GC0124		1
8	Pressure Test Restrictor Elbow	GC0095		1
9	Straight Injector	IN0085	IN0088	2
10	Straight Injector	IN0083	IN0098	1
11	Straight Injector	IN0097	IN0099	1
12	Straight Injector	IN0087	IN0105	1
13	Straight Injector	IN0084	-	1
14	Elbow Injector	IN0103	IN0102	1

NO.	COMPONENT	PART CODE		QTY.
		NATURAL GAS	LPG	
15	Elbow Injector	IN0054	IN0109	1
16	Thermostatic Handset	EL0655		1
17	Power Module Box	IN0672		1
18	Cross Lighting Injector	IN0101	IN0092	1
19	Cross Lighting Burner	GC0181		1
20	Receiver	EL0697		1
21	Control Valve	GC0123K		1
22	Pilot Injector	PI0069	PI0070	1
23	Electrode	P10075		1
24	Thermocouple	PI0074		1



Due to continual technical improvements please check online or with your Gazco retailer for the most up to date parts lists.

Only use Genuine Gazco spares when servicing your appliance.

All of our essential spare parts and consumable items are available to purchase from our webshop at [www.gazcospares.com](http://www.gazcospares.com).

## INFORMATION REQUIREMENT FOR GASEOUS FUEL LOCAL SPACE HEATER

Model		REFLEX 105 MULTI-SIDED BF NG	REFLEX 105 MULTI-SIDED BF LPG
FUEL	Space Heating Emissions (NOx) - mg / kWh <sub>input</sub> (GCV)	130	130

HEAT OUTPUT	Nominal Heat Output - $P_{nom}$	10.0kW	11.1kW
	Minimum Heat Output (indicative) - $P_{min}$	4.4kW	4.2kW

AUXILIARY ELECTRICITY CONSUMPTION	At Nominal Heat Output - $e_{lmax}$	0.003kW	0.003kW
	At Minimum Heat Output - $e_{lmin}$	0.003kW	0.003kW
	In Standby Mode - $e_{lsb}$	0.003kW	0.003kW

USEFUL EFFICIENCY (NCV)	Useful Efficiency at nominal heat output - $\eta_{th,nom}$	89.0%	89.0%
	Useful Efficiency at minimum heat output (indicative) - $\eta_{th,min}$	82.0%	82.0%

PERMANENT PILOT FLAME POWER REQUIREMENT	Permanent Pilot Flame Power requirement (if applicable) - $P_{pilot}$	N/A	N/A
--	---	-----	-----

### TYPE OF HEAT OUTPUT/ROOM TEMPERATURE CONTROL

Electronic room temperature control + day timer + week timer	Yes	Yes
--	-----	-----

### OTHER CONTROL OPTIONS (MULTIPLE SELECTIONS POSSIBLE)

Room temperature control, with presence detection	No	No
Room temperature control, with open window detection	No	No
With distance control option	No	No
With adaptive start control	No	No
With working time limitation	No	No
With black bulb sensor	No	No

ENERGY EFFICIENCY INDEX	86.0%	86.0%
ENERGY EFFICIENCY CLASS	B	B

Contact:	Stovax Gazco Limited, Spitfire Avenue, Skypark, Clyst Honiton, Exeter, Devon, England EX5 2FR
----------	---

**SERVICE RECORDS**

**1ST SERVICE**

Date of Service:.....  
 Next Service Due:.....  
 Signed:.....  
 Retailer's Stamp/GasSafe Registration Number

**3RD SERVICE**

Date of Service:.....  
 Next Service Due:.....  
 Signed:.....  
 Retailer's Stamp/GasSafe Registration Number

**5TH SERVICE**

Date of Service:.....  
 Next Service Due:.....  
 Signed:.....  
 Retailer's Stamp/GasSafe Registration Number

**7TH SERVICE**

Date of Service:.....  
 Next Service Due:.....  
 Signed:.....  
 Retailer's Stamp/GasSafe Registration Number

**9TH SERVICE**

Date of Service:.....  
 Next Service Due:.....  
 Signed:.....  
 Retailer's Stamp/GasSafe Registration Number

**2ND SERVICE - PILOT CHANGE REQUIRED**

Date of Service:.....  
 Next Service Due:.....  
 Signed:.....  
 Retailer's Stamp/GasSafe Registration Number

**4TH SERVICE - PILOT CHANGE REQUIRED**

Date of Service:.....  
 Next Service Due:.....  
 Signed:.....  
 Retailer's Stamp/GasSafe Registration Number

**6TH SERVICE - PILOT CHANGE REQUIRED**

Date of Service:.....  
 Next Service Due:.....  
 Signed:.....  
 Retailer's Stamp/GasSafe Registration Number

**8TH SERVICE - PILOT CHANGE REQUIRED**

Date of Service:.....  
 Next Service Due:.....  
 Signed:.....  
 Retailer's Stamp/GasSafe Registration Number

**10TH SERVICE - PILOT CHANGE REQUIRED**

Date of Service:.....  
 Next Service Due:.....  
 Signed:.....  
 Retailer's Stamp/GasSafe Registration Number

**FOR ENQUIRIES IN THE U.K (EXCLUDING NI):**

Stovax Gazco Limited, Spitfire Avenue, Skypark, Clyst Honiton, Exeter, Devon,  
England EX5 2FR Tel: (01392) 261900 E-mail: info@gazco.com

**FOR ENQUIRIES IN EUROPE (INCLUDING NI):**

Stovax Heating Group (NI) Ltd (Comp reg NI675194), 40 Linenhall Street, Belfast, BT2 8BA  
DX 400 NR Belfast Tel: +44 (0)1392 261990 E-mail: northernireland@gazco.com

